

**RAVEN**

 PRECISION  
*Solutions*



Installation & Service Manual

**Accu-Flow**

### **DISCLAIMER**

While every effort has been made to ensure the accuracy of this document, Raven Industries assumes no responsibility for omissions and errors. Neither is any liability assumed for damages resulting from the use of information contained herein.

Raven Industries shall not be held responsible or liable for the effects of atmospheric conditions and sunspot activity on the performance of our products.

Raven Industries cannot guarantee the accuracy, integrity, continuity, or availability of the GPS signal from the US Department of Defense/NAVSTAR GPS satellites, the OmniSTAR correction service or the WAAS correction service.

Raven Industries accepts no responsibility for the use of the signal for other than the stated purpose. Raven Industries shall not be responsible or liable for incidental or consequential damages or a loss of anticipated benefits or profits, work stoppage or loss or impairment of data arising out of the use or inability to use the Smartrax or any of its components.

# Table of Contents

Symbol Definition .....	2
<b>Chapter 1 - Introduction .....</b>	<b>3</b>
<b>Chapter 2 - Installation .....</b>	<b>5</b>
Assembly of the Accu-Flow System .....	5
Mounting of Accu-Flow System on Implement .....	6
Mounting the Manifold .....	7
Final Plumbing of Accu-Flow System .....	8
Mounting Wheel Drive Speed Sensor .....	10
Mounting the Console and Cabling .....	10
<b>Chapter 3 - Calculation and Operation .....</b>	<b>11</b>
Battery Connections .....	11
Console Features .....	11
Console Calibration .....	11
Calculating "BOOM CAL" .....	12
Calculating "SPEED CAL" .....	12
Calculating "METER CAL" .....	12
Calculating "VALVE CAL" .....	12
Calculating "REQUIRED CAPACITY" .....	13
Console Programming .....	13
Pre-Operational Check-Out .....	14
Operational Check-Out .....	15
<b>Chapter 4 - Troubleshooting .....</b>	<b>17</b>
 APPENDICES	
A. Pressure-Temperature Chart .....	21
B. Accu-Flow Super Cooler .....	23
C. Accu-Flow Troubleshooting Procedure .....	27
D. System Capacity Chart .....	29
E. Recommended Emergency Shut-Off Rope Installation .....	31
F. Flowmeter Maintenance and Adjustment Procedure .....	33
 30 GPM Accu-Flow System On/Off Control Valve Replacement Parts .....	 35
30 GPM Accu-Flow System Fast Valve Replacement Parts .....	36
System Diagrams.....	37

## SYMBOL DEFINITION

GPM	- Gallons per minute	cm	- Centimeters
lit/min	- Liters per minute	dm	- Decimeters
dl/min	- Deciliter per minute	m	- Meter
PSI	- Pounds per square inch	MPH	- Miles per hour
kPa	- Kilopascal	km	- Kilometers
GPA	- Gallon per acre	km/h	- Kilometers per hour
lit/ha	- Liter per hectare	US	- Volume per acre
ml/ha	- Milliliter per hectare	SI	- Volume per hectare
GPK	- Gallons per 1,000 sq. ft.	TU	- Volume per 1,000 sq. ft.
mm	- Millimeters	[]	- Metric numbers
		{}	- 1,000 sq. ft. numbers

## METER CAL CONVERSIONS

To convert the METER CAL number, simply divide the original number (number printed on Flow Meter label) by the desired conversion factor.

**Note:** Newer flowmeters have the Meter Cal included on the meter cal tag for pounds of actual N.

### FOR EXAMPLE:

$$\frac{\text{GALLONS METER CAL No.}}{128} = \text{METER CAL No. for displays in Fluid Ounces}$$

$$\frac{\text{GALLONS METER CAL No.}}{3.785} = \text{METER CAL No. for displays in Liters}$$

$$\frac{\text{GALLONS METER CAL No.}}{4.22} = \text{METER CAL No. for displays in Pounds of actual N}$$

$$\frac{\text{LITERS METER CAL No.}}{.506} = \text{METER CAL No. for displays in kilograms of actual N.}$$

## LIQUID CONVERSIONS

- U.S. Gallons x 128 = Fluid Ounces
- U.S. Gallons x 3.785 = Liters
- U.S. Gallons x 0.83267 = Imperial Gallons
- U.S. Gallons x 8.34 = Pounds (Water)
- U.S. Gallons x 4.22 = Pounds of Actual N
- Liters x .506 = Kilograms of Actual N

## LENGTH

- 1 millimeter (mm) = 0.039 inch
- 1 centimeter (cm) = 0.393 inch
- 1 meter (m) = 3.281 feet
- 1 kilometer (km) = 0.621 mile
- 1 inch = 25.4 millimeters; 2.54 centimeters
- 1 mile = 1.609 kilometers

## PRESSURE

- 1 psi = 6.89 kPa
- 1 kPa = 0.145 psi

## AREA

- 1 square meter = 10.764 square feet
- 1 hectare (ha) = 2.471 acres; 10,000 square meters
- 1 acre = 0.405 hectare; 43,560 square feet
- 1 square mile = 640 acres; 258.9 hectares

## CHAPTER

# 1

## INTRODUCTION

---

The Raven ACCU-FLOW system is designed to work in conjunction with Raven SCS Consoles to provide automatic control of anhydrous ammonia applications. Unlike conventional systems on the market, the ACCU-FLOW system provides continuous and automatic control of anhydrous ammonia regardless of tank pressure, outside temperature, or vehicle speed. Just set the application rate and the Console does the rest.

The ACCU-FLOW system is a complete unit ready to be mounted to your tool bar or field cultivator.

**Notes:**

# CHAPTER

# 2

## Installation

### Assembly of the Accu-Flow System

Assembly the ACCU-FLOW system (P/N 063-0172-991 and 063-0171-157) as shown in the Figures below. All nuts and bolts required for assembly are included.

Use the teflon gasket provided to eliminate possible leaks in the 1" union.

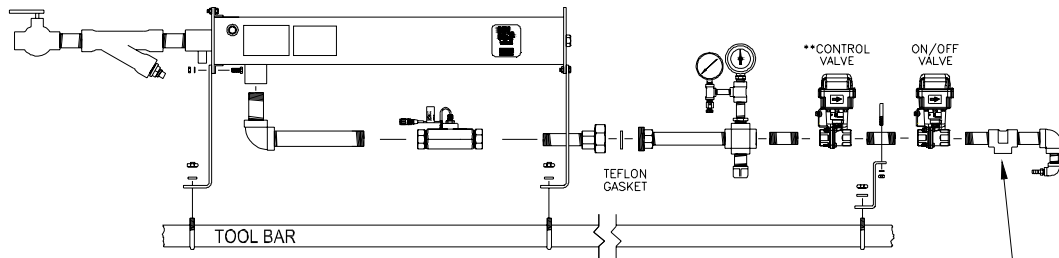

DUAL VALVE SYSTEM  
30 GPM 063-0172-991

SEE "MOUNTING THE MANIFOLD"

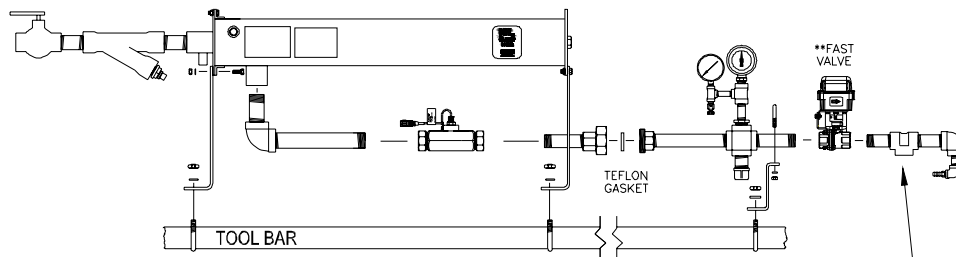

SINGLE VALVE SYSTEM  
30 GPM 063-0171-157

SEE "MOUNTING THE MANIFOLD"

\*\* ITEM NOT SUPPLIED WITH ACCU-FLOW SYSTEM

# Mounting of Accu-Flow System on Implement

The ACCU-FLOW system is mounted directly on the frame of the tool bar or implement as shown in the figure below. Use u-bolts provided for mounting.

## MOUNTING OF ACCU-FLOW SYSTEM ON IMPLEMENT

**MOUNT ACCU-FLOW SYSTEM TO  
IMPLEMENT WITH COOLER INLET  
POINTING TOWARD NURSE TANK  
(REAR OF IMPLEMENT)**

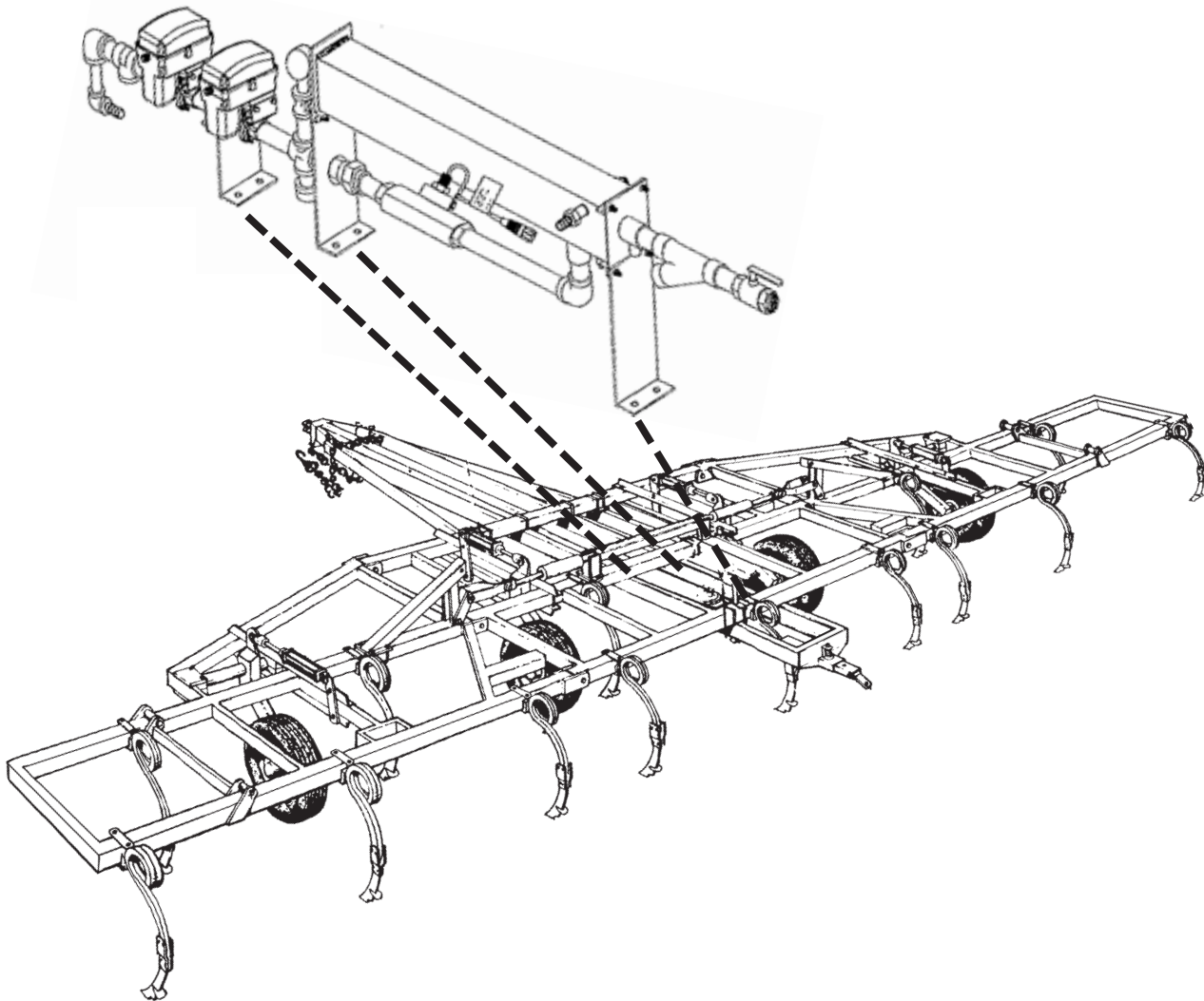



# Mounting the Manifold

See figures below for various ways to attach your existing manifold(s). (Manifold not included) Attach a 0-60 PSI gauge in one outlet of each manifold. Verify that all hose barbs in manifold(s) have same orifice diameter.

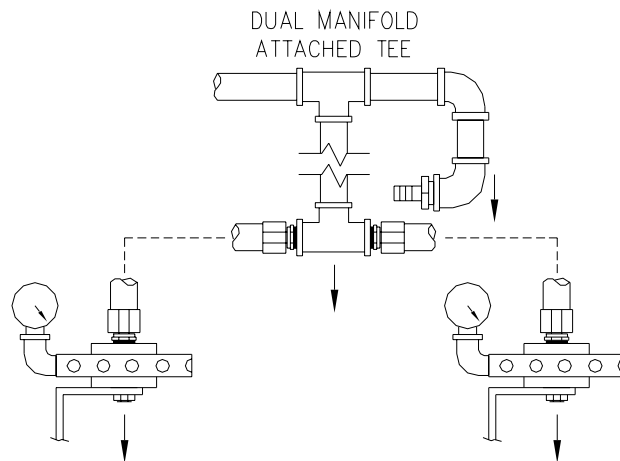
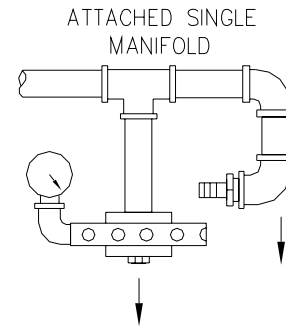
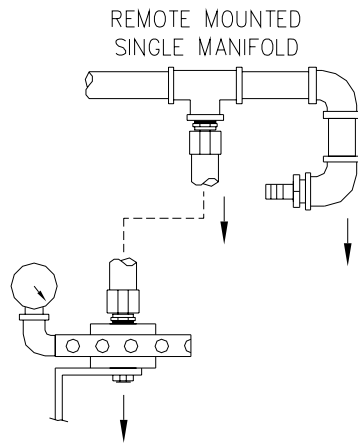

MANIFOLDS MUST BE MOUNTED AT SAME HEIGHT

ARROWS INDICATE THAT THESE ITEMS MUST BE MOUNTED STRAIGHT DOWN.

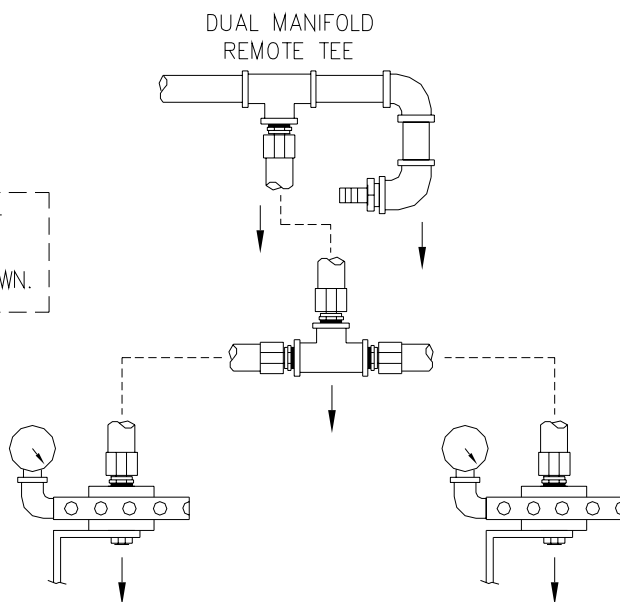

MANIFOLDS MUST BE MOUNTED AT SAME HEIGHT

# Final Plumbing of Accu-Flow System

To complete the plumbing of the ACCU-FLOW system, proceed as follows:

1. Weld the two steel Vapor Tubes provided in the ACCU-FLOW kit to the two center applicator knives as shown in top figure on page 9.
2. Install Flow Meter (RFM 60S) and Control Valve.



**Helpful Hint:** The ON/OFF Valve is not used if a Fast Control Valve is installed.

The Plastic motorized Control Valve used on a liquid system can not be used with  $\text{NH}_3$ . You must use the specially designed motorized Control Valve. This special  $\text{NH}_3$  Valve can also be used with all other chemicals; i.e. herbicides, insecticides, and liquid fertilizer.

3. Connect the two 3/4" I.D. vapor hoses to the hose barbs in the sides of the Heat Exchanger. Connect the two hoses to the two steel vapor tubes.
4. Install the 3/8" I.D. Heat Exchanger hose from the hose barb outlet on the end of the system, to the inlet at the bottom of the Heat Exchanger. The function of the Heat Exchanger is to eliminate vapor and to provide liquid ammonia to the Flow Meter so that it can be accurately measured.
5. Verify that all of the orifice openings in the liquid applicator tubes are unplugged and of the same diameter.
6. Verify that all of the applicator hoses are of equal length from each manifold hose barb to each liquid applicator tube.
7. For high flow systems (20 GPM or greater), it is essential that:
  - a) 1 1/4" hose is used between the nurse tank and emergency shut-off valve.
  - b) The 1 1/4" hose must be as short as possible (less than 15 feet).
  - c) A **1 1/4" break-away coupler** must be installed. A high flow tank valve is also recommended. Do not use street elbows (due to excessive pressure drop).

See Figure on page 9 for example.

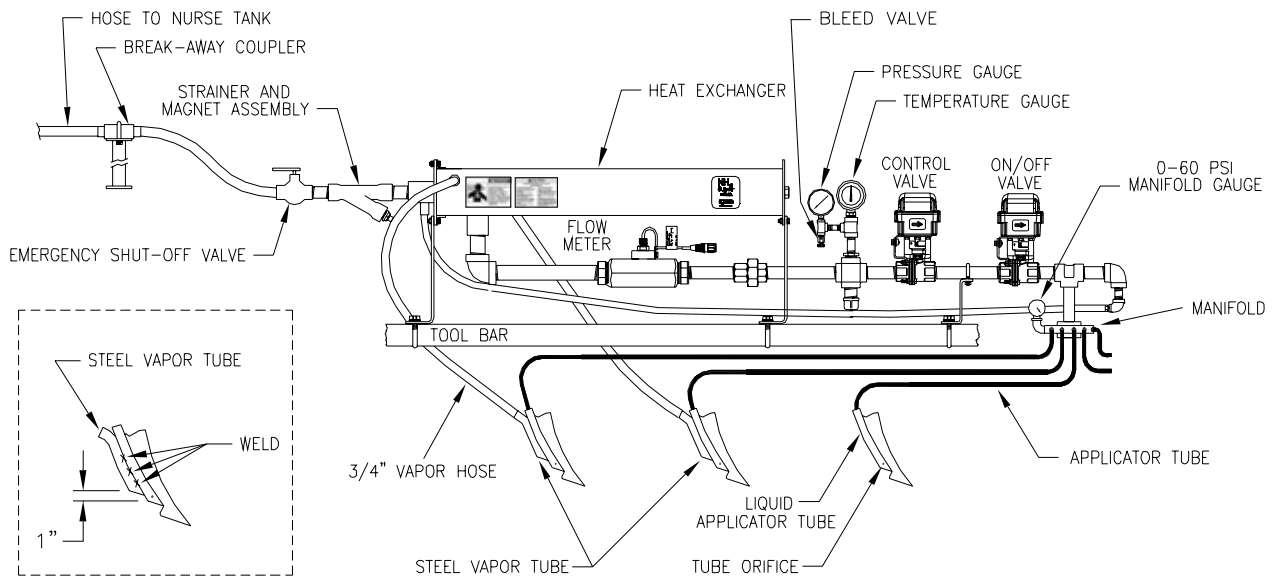

**TYPICAL SYSTEM**

## Mounting the Wheel Drive Speed Sensor

Reference associated SCS Console INSTALLATION AND SERVICE MANUAL.

## Mounting the Console and Cabling

Reference associated SCS Console INSTALLATION AND SERVICE MANUAL.



**Important:** Since the Raven ACCU-FLOW is capable of being installed in conjunction with several different SCS Consoles, it is necessary to make referrals to the appropriate SCS Console Installation and Service Manual.



**Note:** Refer to pages 37- 44 for specific system cable diagrams.

# CHAPTER

# 3

## CALCULATION AND OPERATION

---



**Important:** Since the Raven ACCU-FLOW is capable of being installed in conjunction with several different SCS Consoles, it is necessary to make referrals to the appropriate SCS Console Installation and Service Manual. The following will detail these headlines that can be located in the TABLE OF CONTENTS of the appropriate Installation and Service Manual.

### **Battery Connections**

Reference associated SCS Console INSTALLATION AND SERVICE MANUAL.

### **Console Features**

Reference associated SCS Console INSTALLATION AND SERVICE MANUAL.

### **Console Calibration**

Reference associated SCS Console INSTALLATION AND SERVICE MANUAL.

## Calculating “BOOM CAL”

Reference associated SCS Console INSTALLATION AND SERVICE MANUAL.

Implement width = Number of applicators knives x Spacing in inches [cm].

## Calculating “SPEED CAL”

Reference associated SCS Console INSTALLATION AND SERVICE MANUAL.

## Calculating “METER CAL”

To display application rate in pounds per acre of actual N (PPAN), or kilograms per hectare of actual N [KgPh], divide original METER CAL by 4.22 [.506], and use the figure obtained as new METER CAL number. You must round to the nearest 3 digit whole number.

**EXAMPLE:** Assume METER CAL number is 720 [190].

Pounds:

$$\text{Adjusted Meter Cal} = \frac{720}{4.22} = 170.6$$

Kilograms:

$$\text{Adjusted Meter Cal} = \frac{190}{.506} = 375.5$$

The number to enter for the METER CAL is 171 [375]. Enter target application rate in pounds per acre of actual N (PPAN), or kilograms per hectare of actual N [KgPh].



**Important:** All volumes will be displayed in Pounds (Kg) of Actual N.

## Calculating “VALVE CAL”

Reference associated SCS Console INSTALLATION AND SERVICE MANUAL.



**Note:** Valve CAL number may need an adjustment to obtain control particularly at low flow rates.

## Calculating “REQUIRED CAPACITY”

The target application rate which you program into the SCS Console is in “Pounds Per Acre of Actual N (PPAN)”, as is most often associated with NH<sub>3</sub>.

After determining the PPAN application rate, calculate the total pounds per minute of actual N (PPMN) flow of the system to ensure that the system capacity is not exceeded. To make this calculation, use the following formula:

$$\text{PPMN [KPMN]} = \frac{\text{PPAN [KgPh]} \times \text{MPH [KPH]} \times \text{Implement Width (inches) [cm]}}{(5,940) [60,000]}$$

PPAN [KgPh]	= Target Application Rate
MPH [KPH]	= Target Vehicle Speed
Implement Width	= Number of Applicator Knives x Spacing (in inches)
PPMN	= Required Capacity of the System

### EXAMPLE:

#### ENGLISH UNITS:

$$\text{PPMN} = \frac{150 \times 5.5 \times 480}{(5,940)} = 66.6$$

#### METRIC UNITS:

$$\text{KPMN} = \frac{[68] \times [10] \times [1220]}{[60,000]} = 13.8$$

PPMN = 67 Pounds Per Minute

KPMN = 14 Kilograms Per Minute

The maximum capacity of the 30 GPM system is 126 PPMN [57 KPMN]. Consult factory if maximum rate is exceeded.

## Console Programming

Reference associated SCS Console INSTALLATION AND SERVICE MANUAL.

## Pre-Operational Check-Out

Complete the following pre-operational check-out before proceeding:

1. Verify that all hoses, fittings, and mounting bolts are secure.
2. Verify that the SCS Cable Assembly is attached to the connector on the Flow Meter.
3. Verify that the SCS Cable Assembly is attached to the motorized Control Valve connector.
4. Turn Console MASTER switch OFF.
5. Open completely the Emergency Shut-Off Valve.
6. Close all bleed ports.
7. Connect and secure nurse tank hose to implement.
8. Open slightly the nurse tank shut-off valve.
9. Inspect the system for leaks. If none, proceed to Step 11.
10. If leaks are present, close the nurse tank shut-off valve. Open bleed port (Refer to Typical System figure on page 9) to exhaust all  $\text{NH}_3$  in the lines. Allow at least 30 minutes for system to bleed off. The cooler should not feel cold. Verify that the pressure gauge reading on the ACCU-FLOW system is zero. After all lines have been completely exhausted, disconnect nurse tank hose (**USE CAUTION**). Correct leaks and repeat Steps 7 thru 10.
11. Verify that the pressure gauge reading (if installed) on the ACCU-FLOW system compares to that on the nurse tank. If not, one of the gauges is defective and should be replaced.
12. Fully open nurse tank shut-off valve.

**IMPORTANT:** REVIEW THE SAFETY REQUIREMENTS ASSOCIATED WITH THE HANDLING AND APPLICATION OF ANHYDROUS AMMONIA WITH YOUR LOCAL  $\text{NH}_3$  SUPPLIER.





## Operational Check-Out

After you have completed the PRE-OPERATIONAL CHECK-OUT, you are ready to go to the field. To quickly verify that the system is working properly in the field, complete the following operational check-out:

1. Verify that the correct Boom Widths, SPEED CAL, METER CAL, VALVE CAL, and RATE CALS have been entered correctly into the Console.
2. Place Console switch to MAN.
3. MASTER ON/OFF switch positioned to OFF.
4. BOOM 1 switch ON (if dual manifold is used, BOOM 1 and BOOM 2 should be ON). Shut off remaining BOOM switches.
5. Drive down field at target speed with MASTER ON/OFF switch OFF to verify SPEED read-out on the Console.
6. With applicator knives in the ground, place MASTER ON/OFF switch to ON.
7. While driving in the field, manually adjust the flow with the INC/DEC switch until target RATE is obtained. **The manifold pressure must be greater than 10 PSI at this time for proper operation.**
8. Select automatic mode of operation, the system will now automatically maintain the target RATE regardless of vehicle speed. If not, see TROUBLESHOOTING GUIDE, Problem 12.
9. After two minutes of operation, record the system temperature and pressure from the two gauges mounted near the motorized Control Valve. These readings must be obtained while you are actually apply the NH<sub>3</sub>. Readings will be incorrect if the system is shut off, even momentarily. Find the intersection point of these two readings on the PRESSURE-TEMPERATURE chart in Appendix A. This point must be located in the NON-VAPOR area (above the line). If it is not, see TROUBLESHOOTING GUIDE, Problem 17.  
**EXAMPLE:** Pressure reading 70 PSI and temperature reading 40 F. The point where these two readings intersect is the NON-VAPOR area. See Appendix A.
10. Clean magnets in Strainer and Magnet Assembly after every 4 or 5 tank loads (at minimum) of NH<sub>3</sub>.



**Important:** Perform system bleed procedure found on page 24.

11. If an additive such as N-Serve (Dow Chemical), or ACA (Amoco) is used, it may require periodic cleaning of the Flowmeter by disassembling the Flowmeter. See Appendix F.

## CHAPTER

# 4

## TROUBLESHOOTING

---

**Problem 1:** No display lights with power ON.

**Solutions:**

1. Check fuse on back of Console.
2. Check battery connections.
3. Check operation of POWER ON/OFF switch.
4. Return Console to your Dealer to replace Processor Board Assembly.

**Problem 2:** All keyboard lights on at same time.

**Solution:**

1. Return Console to your Dealer to replace Face Plate Subassembly.

**Problem 3:** A digit cannot be entered via keyboard.

**Solution:**

1. Return Console to your Dealer to replace Face Plate Subassembly.

**Problem 4:** An indicator light on a key will not illuminate.

**Solution:**

1. Return Console to your Dealer to replace Face Plate Subassembly and/or Processor Board Assembly.

**Problem 5:** Console displays flashing "CAL" whenever vehicle engine is started.

**Solution:**

1. Check battery voltage and battery connections.

**Problem 6:** Console displays flashing “CAL” whenever master switch is turned ON or OFF.

**Solution:**

1. Check battery voltage and battery connections.

**Problem 7:** “TIME” function is inaccurate or drifting.

**Solution:**

1. Return Console to Dealer to replace Processor Board Assembly.

**Problem 8:** One display digit has one or more missing segments.

**Solution:**

1. Return Console to Dealer to replace LCD Display Board Assembly.

**Problem 9:** Speed display “0”.

**Solutions:**

1. Check Speed Sensor Cable connector and plug on back of Console for loose pins.
2. Clean pins and sockets on Speed Sensor cable connectors.
3. If no extension cable is used, replace Speed Sensor Switch Assembly.

**Problem 10:** Speed inaccurate or unstable (Wheel Drive Speed Sensor).

**Solutions:**

1. Run speed check on hard surface road. If SPEED is accurate, investigate mounting Speed Sensor on different wheel.
2. Remove one red magnet and one black magnet from the wheel. (Reposition remaining red and black magnets directly across from each other). Enter a SPEED CAL number in the Console twice as large as the correct SPEED CAL number. Run speed check on hard surface road. Remove these two magnets and replace with other two. Run speed check. If SPEED is inaccurate with only one set of magnets, replace the bad set. If SPEED is inaccurate with both sets, replace Speed Sensor Assembly.

**NOTE:** Re-enter original SPEED CAL number after testing is complete.

**Problem 11:** Rate Reads “0000”.**Solutions:**

1. Verify SPEED is registering accurately. If SPEED is zero, refer to Troubleshooting Problem 10.
2. Verify TOTAL VOLUME is registering flow. If not, refer to Troubleshooting Problem 14.

**Problem 12:** Rate inaccurate or unstable.**Solutions:**

1. Verify that all numbers “keyed in” Console are correct. Verify SPEED is registering accurately. If SPEED is inaccurate, refer to Troubleshooting Problem 10.
2. In MAN (manual) operation, verify that RATE display holds constant. If not, refer to Troubleshooting Problem 17.
3. Verify plumbing with a maximum of 15’ of 1 1/4” hoses and 1 1/4” breakaway.



**Important:** Perform system bleed procedure prior to maintenance (see page 24).

4. Remove any street elbows and replace with a conventional elbow and nipple.
5. Verify that the tank has a high flow valve.

**Problem 13:** Cannot vary rate in manual operation or in AUTO.**Solutions:**

1. Check cabling to motorized Control Valve for breaks.
2. Check connections in cabling for cleanliness.
3. Verify that there is voltage at the valve connector by placing MASTER switch ON; RATE 1/RATE 2/MAN switch to MAN; and POWER switch to ON. Manually operate INC/DEC switch to verify voltage.
4. Verify that valve is turning by looking at coupler shaft. If not, replace control valve motor.

**CAUTION:** Bleed system thoroughly prior to disassembling of system.

**Problem 14:** Total Volume does not register.**Solutions:**

1. Check Flow Meter cable for breaks and shorts. See Console Installation Manual for test procedure.
2. Check internals of Flow Meter; clean and adjust. See Console Installation Manual for Flow Meter cleaning and adjustment.



**Important:** Perform system bleed procedure prior to maintenance (see page 24).

**Problem 15:** Total Volume Registers Flow Inaccurately.

**Solutions:**

1. Verify that arrow on Flow Meter is pointing in direction of flow.
2. Clean Flow Meter according to Appendix F.
3. See Appendix in Console Installation Manual.

**Problem 16:** Motorized Control Valve rotates more than 1/4 turn.

**Solution:**

1. Replace motorized Control Valve.

**Problem 17:** Pressure vs. Temp. operating point located in the vapor area chart.

**Solutions:**

1. Verify that the vapor tubes have been affixed to the applicator knives correctly and that their openings are not plugged.
2. Disassemble and clean Heat Exchanger if additives such as N-Serve or ACA are being used. See Appendix B.
3. Determine if pressure drop is within limits. See Appendix C.

# APPENDIX



## PRESSURE-TEMPERATURE CHART

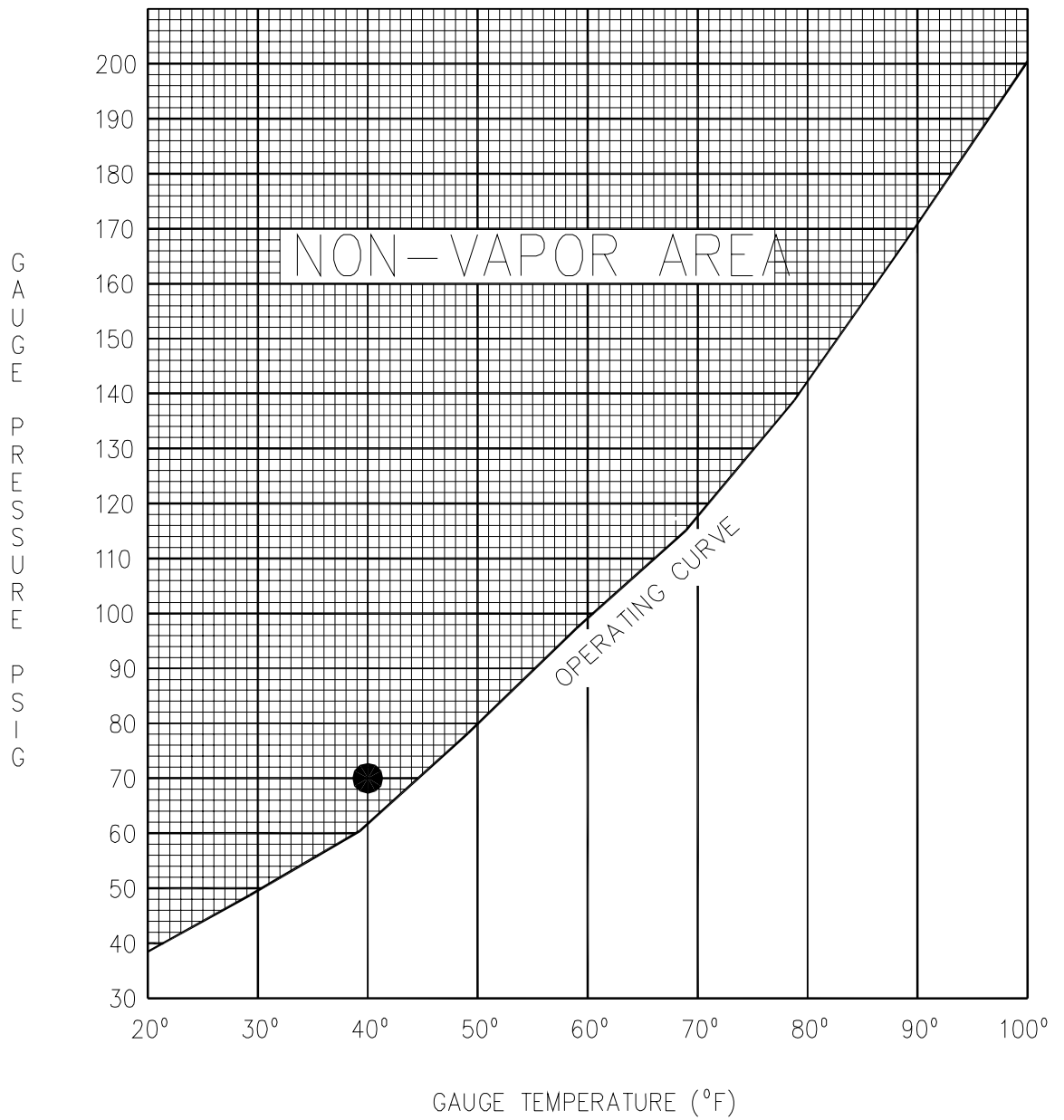

● = EXAMPLE FROM PAGE 15

**Notes:**



# APPENDIX

# B

## ACCU-FLOW SUPER COOLER

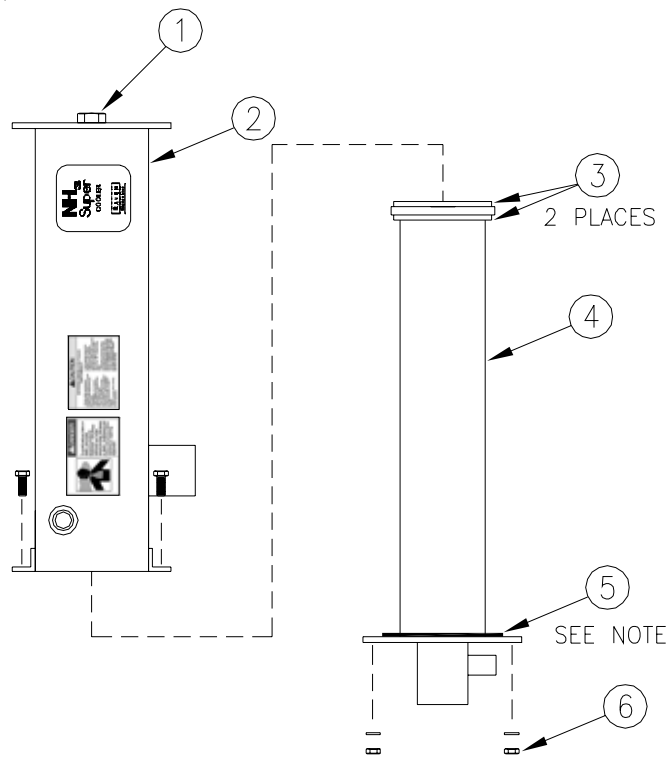

063-0172-877 (30 GPM)

ITEM	DESCRIPTION	PART #
1	Relief Valve	334-0002-005
2	Outer Assembly (30 GPM)	116-0159-683
3	O-Ring	219-0000-036
4	Inner Assembly (30 GPM)	116-0159-430
5	Gasket	219-0000-143
6	3/8"-16 Hex Nut	312-1001-037



**Note:** Accuflow super cooler of (P/N 063-0159-837 and 063-0159-546), use Gasket Retainer Kit 117-0171-121. Gaskets only (P/N 219-0000-142C and 219-0000-144).

## MAINTENANCE INSTRUCTIONS

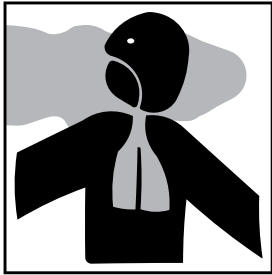
	<p style="text-align: center;"><b>⚠ DANGER</b></p> <p>To avoid serious injury or death, use proper personal protective equipment. Anhydrous ammonia can cause severe burning, blindness or death. Understand and follow instructions before operating or repairing equipment.</p>	<p style="text-align: center;"><b>⚠ CAUTION</b></p> <p style="text-align: center;"><b>ANHYDROUS AMMONIA (Under Pressure) READ CAREFULLY</b></p> <table border="0"> <tr> <td style="vertical-align: top;"> <ol style="list-style-type: none"> <li>1. Review safety requirements associated with anhydrous ammonia &amp; ACCU-FLOW manual with your NH3 supplier.</li> <li>2. Wear goggles, face shield &amp; rubber gloves for changing tanks and/or making repairs.</li> <li>3. Have five (5) gallons of clean water available in case of exposure.</li> <li>3. Flush eyes or skin immediately with large quantities of water if exposed.</li> <li>4. Stand 'up wind' when working around equipment.</li> </ol> </td> <td style="vertical-align: top;"> <ol style="list-style-type: none"> <li>5. Park equipment away from buildings or other hazards.</li> <li>6. Before leaving equipment unattended, always close nurse tank main valve, close cooler shutoff valve &amp; turn 'OFF' console power switch.</li> <li>7. Disconnect nurse tank hose &amp; thoroughly bleed all system lines before starting repairs (see manual). <b>ALLOW A MINIMUM OF ONE HOUR TO FULLY BLEED SYSTEM! VERIFY NO GAGE PRESSURE PRESENT BEFORE STARTING.</b></li> </ol> </td> </tr> </table>	<ol style="list-style-type: none"> <li>1. Review safety requirements associated with anhydrous ammonia &amp; ACCU-FLOW manual with your NH3 supplier.</li> <li>2. Wear goggles, face shield &amp; rubber gloves for changing tanks and/or making repairs.</li> <li>3. Have five (5) gallons of clean water available in case of exposure.</li> <li>3. Flush eyes or skin immediately with large quantities of water if exposed.</li> <li>4. Stand 'up wind' when working around equipment.</li> </ol>	<ol style="list-style-type: none"> <li>5. Park equipment away from buildings or other hazards.</li> <li>6. Before leaving equipment unattended, always close nurse tank main valve, close cooler shutoff valve &amp; turn 'OFF' console power switch.</li> <li>7. Disconnect nurse tank hose &amp; thoroughly bleed all system lines before starting repairs (see manual). <b>ALLOW A MINIMUM OF ONE HOUR TO FULLY BLEED SYSTEM! VERIFY NO GAGE PRESSURE PRESENT BEFORE STARTING.</b></li> </ol>
<ol style="list-style-type: none"> <li>1. Review safety requirements associated with anhydrous ammonia &amp; ACCU-FLOW manual with your NH3 supplier.</li> <li>2. Wear goggles, face shield &amp; rubber gloves for changing tanks and/or making repairs.</li> <li>3. Have five (5) gallons of clean water available in case of exposure.</li> <li>3. Flush eyes or skin immediately with large quantities of water if exposed.</li> <li>4. Stand 'up wind' when working around equipment.</li> </ol>	<ol style="list-style-type: none"> <li>5. Park equipment away from buildings or other hazards.</li> <li>6. Before leaving equipment unattended, always close nurse tank main valve, close cooler shutoff valve &amp; turn 'OFF' console power switch.</li> <li>7. Disconnect nurse tank hose &amp; thoroughly bleed all system lines before starting repairs (see manual). <b>ALLOW A MINIMUM OF ONE HOUR TO FULLY BLEED SYSTEM! VERIFY NO GAGE PRESSURE PRESENT BEFORE STARTING.</b></li> </ol>			

### ACCUFLOW SYSTEM BLEED PROCEDURE

**Note:** This procedure must be completed prior to any repairs or maintenance.

1. Wear/use proper personal protective equipment, i.e. rubber gloves, goggles, face shield, long sleeves.
2. Verify master switch on console is 'OFF' and switch console power to 'OFF'.
3. Close nurse tank shut-off valve and cooler inlet shut-off valve.
4. Bleed and disconnect the nurse tank supply hose from the Accuflow system.
5. Slowly open the cooler inlet shut-off valve (make sure the nurse tank disconnect coupler does not leak).
6. While standing upwind, slowly open cooler bleed valve to full open (see Typical System figure found on page 9).
7. Allow 60 minutes for system to fully bleed out.
8. Verify that the cooler gauge pressure is zero and the cooler is not cold to the touch (insure that all NH3 liquid has converted to vapor).

### STORAGE INSTRUCTIONS

Clean inside with Kerosene and coat with a good grade of motor oil at end of each season.

### REMOVAL OF SUPER COOLER FROM SYSTEM

1. Perform ACCU-FLOW system bleed procedure.
2. Remove all external plumbing from Super Cooler.
3. Remove Super cooler from bracket mount (4 bolts).

## **DISASSEMBLY/ASSEMBLY OF SUPER COOLER**

1. Clamp Super Cooler in vise with relief valve up.
2. Remove four (4) bolts from base.
3. Remove Inner Assembly with a twist-pull motion. Use CAUTION, DO NOT FORCE.
4. Clean residue from Inner Assembly and inspect Outer Assembly.
5. Replace two (2) O-Rings. Lubricate O-Rings with brake fluid when installing and reassembling.
6. Assemble in reverse order.

**Notes:**

## APPENDIX

## C

---

**ACCU-FLOW TROUBLESHOOTING PROCEDURE**

---

**Problem:** Inaccurate measurements

(System indicates more than the amount removed from tank)

1. Record operating temperature, operating pressure, and static tank pressure from Temperature and Pressure gauges on ACCU-FLOW. See page 9 for location of gauges.
2. Verify that operating temperatures and pressure point lies to the left of operating curve. See **Pressure-Temperature Chart**, Appendix A. If to the left of operating curve, clean Flow Meter and check cables and proceed to Step 4. If not, proceed to Step 3.
3. Operating temperature and pressure point lies on the operating curve of the Pressure-Temperature Chart, see **System Capacity Chart**, Appendix D, to determine the maximum speed allowance for application. If maximum speed is exceeded, reduce speed, if not, proceed with Step 5.
4. Review plumbing of system per recommended procedure (see figure on page 9). If not similar to drawing, re-plumb system. If plumbed correct, proceed to Step 5.
5. Using the static pressure and operating pressure reading obtained in Step 1, verify that the difference does not exceed 5 PSI. If greater than 5 PSI, proceed with Step 6, if not, proceed with Step 7.
6. Clean strainer next to the Heat Exchanger. Check hoses for deterioration, replace if necessary. Remove all excess hose length between tank and break-away coupler, (typically 12 feet), also excess hose between break-away coupler and system, (typically 3 feet). Verify that break-away coupler is 1 1/4", not 1". If correct, proceed to Step 7.

7. Check Heat Exchanger cooling chamber by removing the vapor hoses from the steel vapor tubes at applicator knife. Secure hose end so it can be viewed from vehicle. Drive vehicle a short distance (1/2 minute). Verify a heavy stream of anhydrous ammonia vapor is visible from each hose end. If not, disassemble and clean Heat Exchanger.

# APPENDIX

# D

## SYSTEM CAPACITY CHART

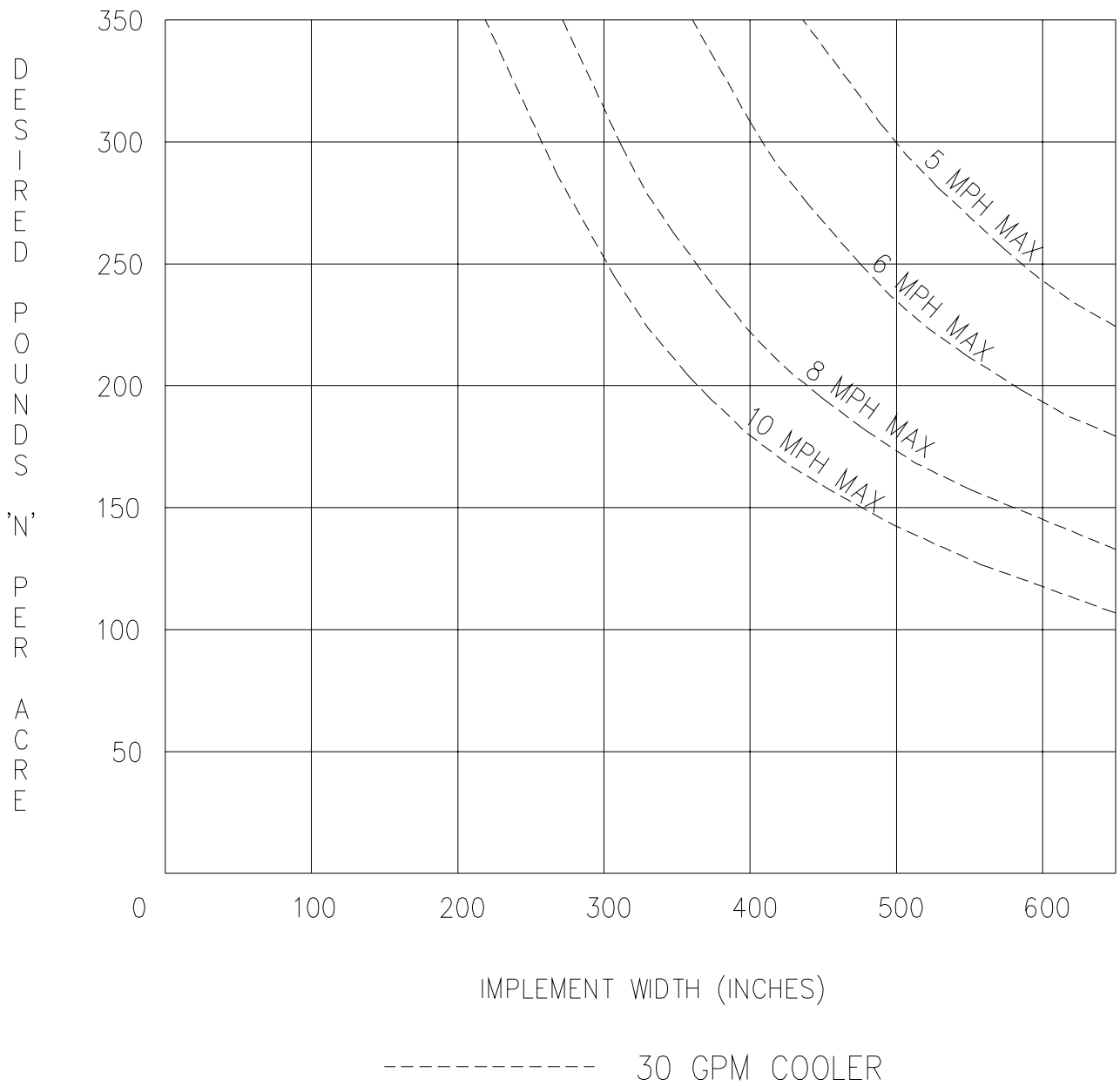

**Notes:**



# E

## RECOMMENDED EMERGENCY SHUT-OFF ROPE INSTALLATION



**IMPORTANT:** ALWAYS WORK UPWIND OF NH<sub>3</sub> IMPLEMENT.

USE SAFETY ROPE (NOT PROVIDED) TO SHUT OFF HAND VALVE BETWEEN COOLER AND NURSE TANK.

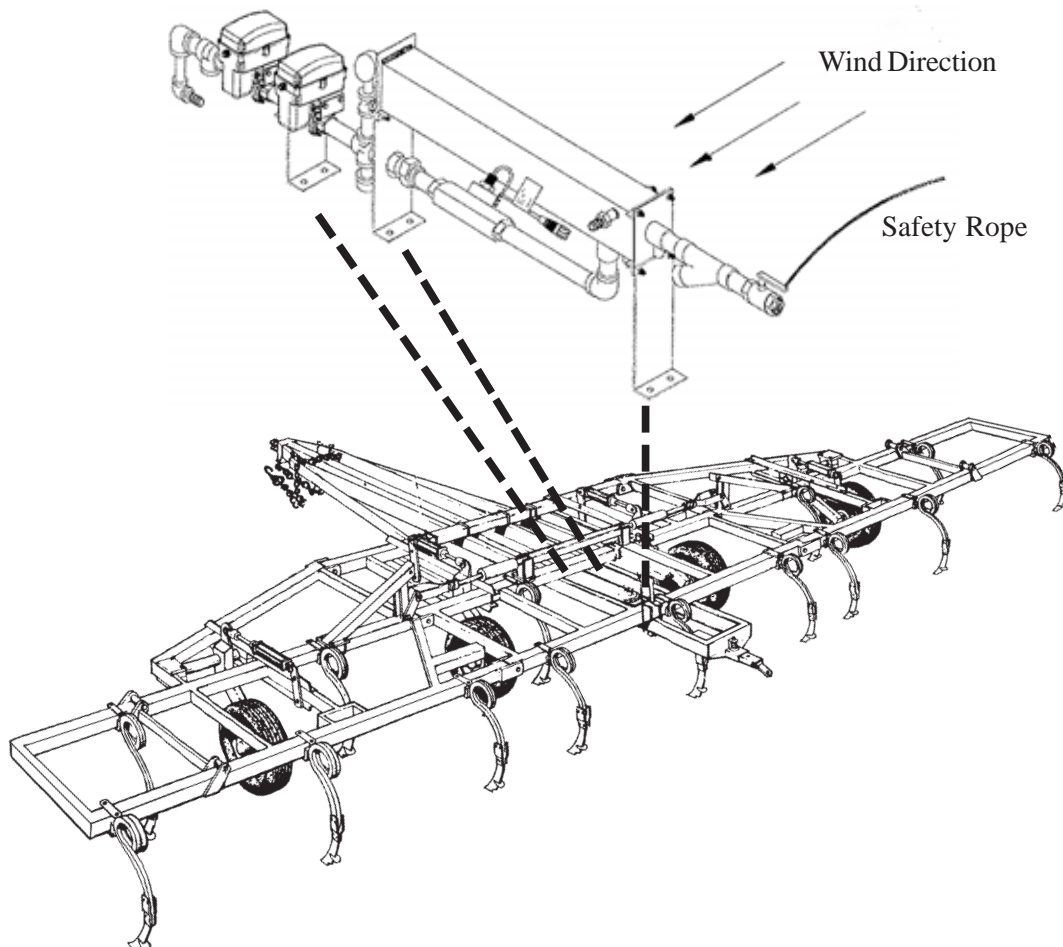

**Notes:**

## APPENDIX

## F

## FLOW METER MAINTENANCE AND ADJUSTMENT PROCEDURE

---



**Important:** Perform system bleed procedure prior to maintenance (see page 24).

1. Remove Flow Meter from tool bar, brush away any debris and remove any foreign material.
2. Remove the retaining rings carefully. Remove the bearing hub, turbine hub, and turbine from inside Flow Meter housing.
3. Clean the turbine and hubs of metal filings and any other foreign material. Use pressurized air to blow metal filings and debris out of both hubs and turbine. Confirm that the turbine blades are not worn. Hold turbine and bearing hub in your hand and spin turbine. It should spin freely with very little drag.
4. If bearing hub stud is adjusted or replaced, verify the turbine fit before reassembling: Put turbine hub and retaining ring in place. Put bearing but with turbine against turbine hub inside the flow-meter housing. (Stud keys inside flowmeter housing must be lined up in the groove on the hub). Put the retaining ring on to lock bearing hub in place. Spin turbine by blowing on it. Tighten bearing hub stud until turbine stalls. Loosen the stud 1/3 of a turn. The turbine should spin freely.

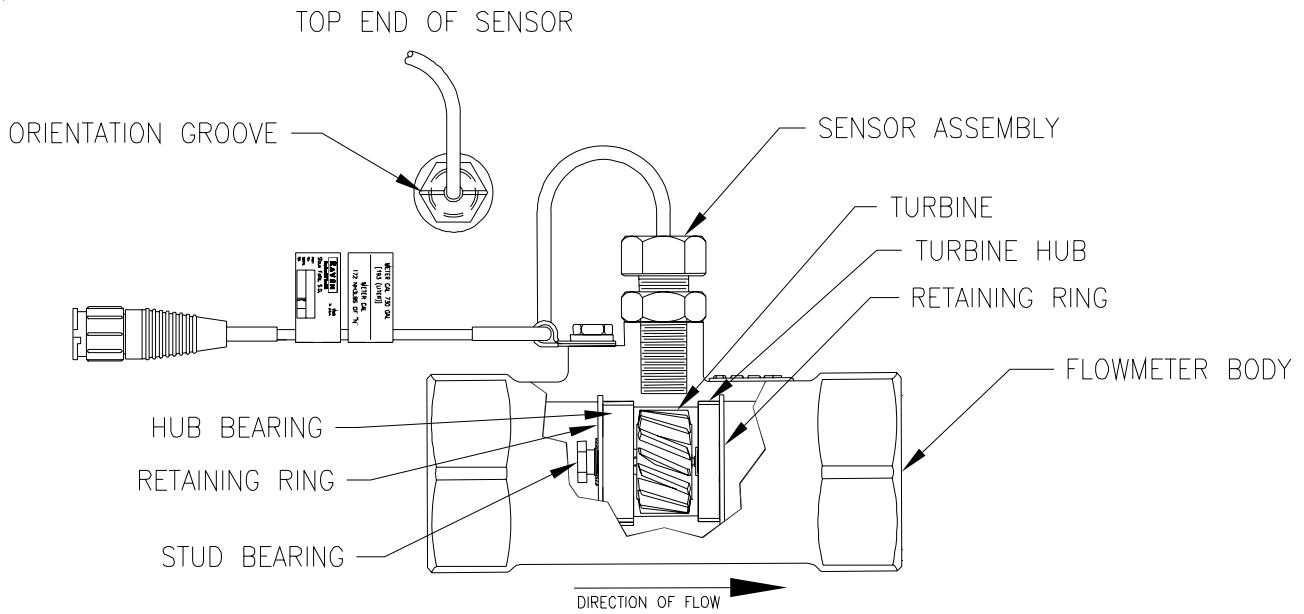

5. Use a low pressure (5 psi) [34.5 kPa] jet of air thru Flow Meter in the direction of flow and again in the opposite direction to verify that the turbine spins freely. If there is drag, loosen the stud on the bearing hub 1/16 turn until the turbine spins freely.
6. If turbine spins freely and the cables have checked out O.K., but the Flow Meter is not totalizing properly, verify that the sensor is threaded all the way into the flowmeter body, and the orientation groove on top of the sensor is parallel with flowmeter body. If flowmeter still does not totalize, replace Sensor Assembly.

# 30 GPM ACCU-FLOW SYSTEM ON/OFF CONTROL VALVE REPLACEMENT PARTS

063-0172-991

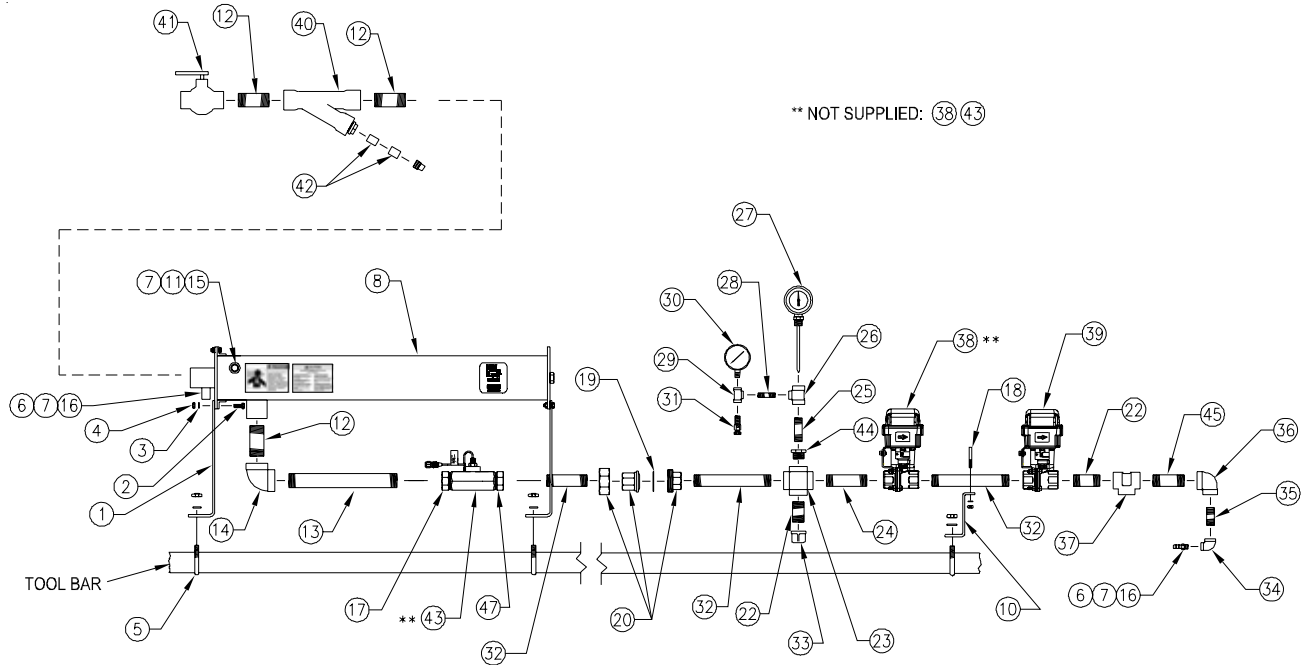

\*\* NOT SUPPLIED: (38) (43)

**\*\* High Pressure NH<sub>3</sub> Plumbing Should Be Done With Schedule 80 Pipe And Fittings \*\***

ITEM	DESCRIPTION	RAVEN PART #	ITEM	DESCRIPTION	RAVEN PART #
1	Cooler Bracket	107-0171-063	26	1/2" x 1/2" x 1/4" Pipe Tee	333-0004-009
2	3/8"-16 x 1 3/4" Bolt	311-0054-108	27	Temperature Gauge	417-0001-009
3	3/8" Lock Washer	313-1000-022	28	1/4" x 2" Pipe Nipple	333-0008-002
4	3/8"-16 Hex Nut	312-1001-037	29	1/4" Pipe Tee	333-0004-001
5	U-Bolt Assembly	107-0159-447	30	0-150 PSI Gauge	417-0001-008
6	3/8" EVA Hose	214-0001-002	31	1/4" Bleed Valve	334-0001-012
7	Hose Clamp	435-3003-002	32	1" x 8" Pipe Nipple	333-0008-034
8	Super Cooler (30 GPM)	063-0172-877	33	1" Pipe Cap	333-0009-090
10	Z-Bracket	107-0171-068	34	1/2" x 1/4" Pipe Elbow	333-0005-009
11	1/2" x 3/4" Hose Barb	333-0002-011	35	1/2" x 2" Pipe Nipple	333-0008-016
12	1 1/4" x 2" Pipe Nipple	333-0008-038	36	1" x 1/2" Pipe Elbow	333-0005-010
13	1 1/4" x 12" Pipe Nipple	333-0008-044	37	1" Pipe Tee	333-0004-005
14	1 1/4" Elbow	333-0005-006	38	Control Valve	063-0172-977
15	3/4" EVA Hose	214-0001-005	39	On/Off Valve	063-0172-978
16	1/4" x 3/8" Hose Barb	333-0002-004	40	1 1/4" Y-Strainer	333-9000-025
17	1 1/2" X 1 1/4" Bushing	333-0003-019	41	1 1/4" Steel Ball Valve	019-0159-245
18	1 1/2" Muffler Clamp	435-3003-030	42	Ceramic Magnets	418-0000-001
19	1" Pipe Union Gasket	219-0000-076	43	Flow Meter, 60S	063-0171-666
20	1" Pipe Union	333-0006-004	44	1" x 1/2" Reducing Bushing	333-0003-094
22	1" x 2" Pipe Nipple	333-0008-029	45	1" x 3" Pipe Nipple	333-0008-031
23	1" Pipe Cross	333-0004-029	46	Vapor Tubes (Not Shown)	214-0002-002
24	1" x 5" Pipe Nipple	333-0008-033	47	1 1/2" x 1" Bushing	333-0003-020
25	1/2" x 1 1/2" Pipe Nipple	333-0008-015			

054-0159-117

# 30 GPM ACCU-FLOW SYSTEM FAST VALVE REPLACEMENT PARTS

063-0171-157

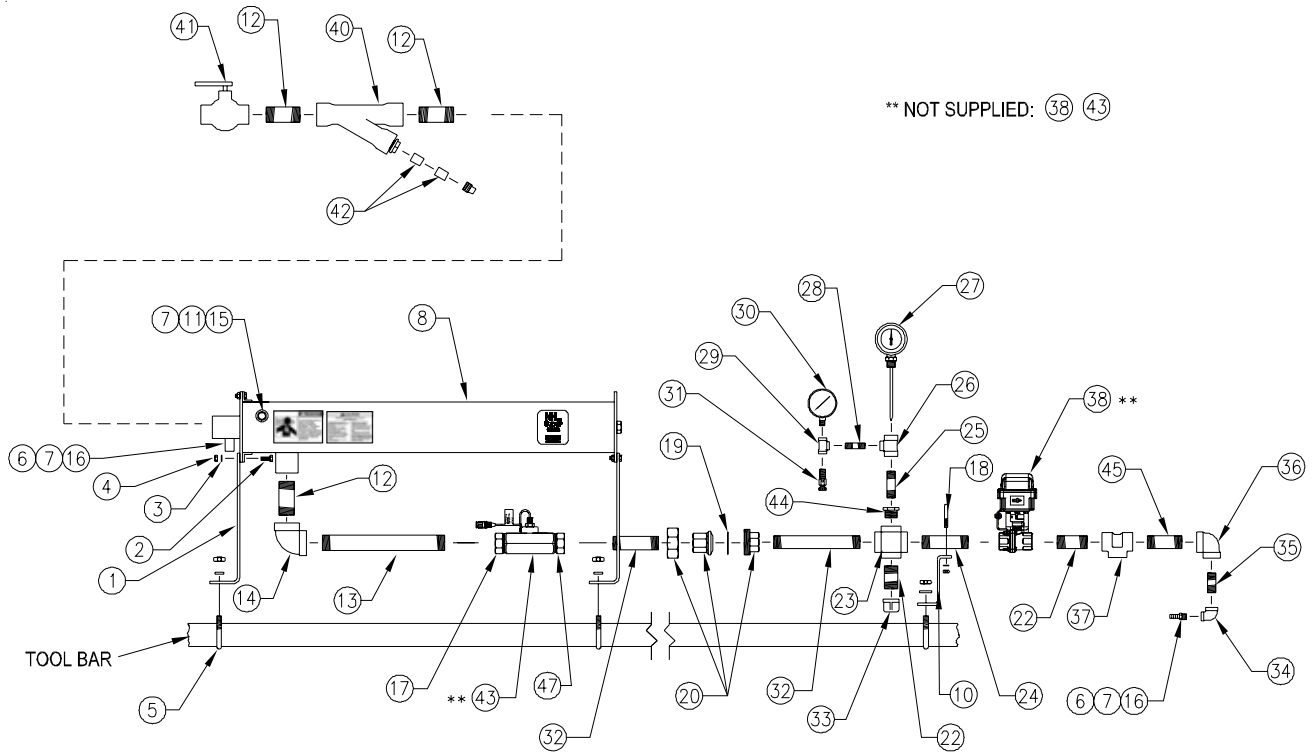

\*\* NOT SUPPLIED: (38) (43)

**\*\* High Pressure NH<sub>3</sub> Plumbing Should Be Done With Schedule 80 Pipe And Fittings \*\***

ITEM	DESCRIPTION	RAVEN PART #	ITEM	DESCRIPTION	RAVEN PART #
1	Cooler Bracket	107-0171-063	26	1/2" x 1/2" x 1/4" Pipe Tee	333-0004-009
2	3/8"-16 x 1 1/4" Bolt	311-0054-106	27	Temperature Gauge	417-0001-009
3	3/8" Lock Washer	313-1000-022	28	1/4" x 2" Pipe Nipple	333-0008-002
4	3/8"-16 Hex Nut	312-1001-037	29	1/4" Pipe Tee	333-0004-001
5	U-Bolt Assembly	107-0159-447	30	0-150 PSI Gauge	417-0001-008
6	3/8" EVA Hose	214-0001-002	31	1/4" Bleed Valve	334-0001-012
7	Hose Clamp	435-3003-002	32	1" x 8" Pipe Nipple	333-0008-034
8	Super Cooler (30 GPM)	063-0172-877	33	1" Pipe Cap	333-0009-090
10	Z-Bracket	107-0171-068	35	1/2" x 2" Pipe Nipple	333-0008-016
11	1/2" x 3/4" Hose Barb	333-0002-011	36	1" x 1/2" Pipe Elbow	333-0005-010
12	1 1/4" x 2" Pipe Nipple	333-0008-038	37	1" Pipe Tee	333-0004-005
13	1 1/4" x 12" Pipe Nipple	333-0008-044	38	Fast Valve	063-0172-979
14	1 1/4" Elbow	333-0005-006	39	1 1/4" Y-Strainer	333-9000-025
15	3/4" EVA Hose	214-0001-005	41	1 1/4" Steel Ball Valve	019-0159-245
16	1/4" x 3/8" Hose Barb	333-0002-004	42	Ceramic Magnets	418-0000-001
17	1 1/2" x 1 1/4" Bushing	333-0003-019	43	Flow Meter, 60S	063-0171-666
18	1 1/2" Muffler Clamp	435-3003-030	44	1" x 1/2" Reducing Bushing	333-0003-094
19	1" Pipe Union Gasket	219-0000-076	45	1" x 3" Pipe Nipple	333-0008-031
20	1" Pipe Union	333-0006-004	46	Vapor Tubes (Not Shown)	214-0002-002
22	1" x 2" Pipe Nipple	333-0008-029	47	1 1/2" x 1" Bushing	333-0003-020
23	1" Pipe Cross	333-0004-029			
24	1" x 5" Pipe Nipple	333-0008-033			
25	1/2" x 1 1/2" Pipe Nipple	333-0008-015			

### SCS 440 WITH ACCUFLOW, 2 VALVE SYSTEM

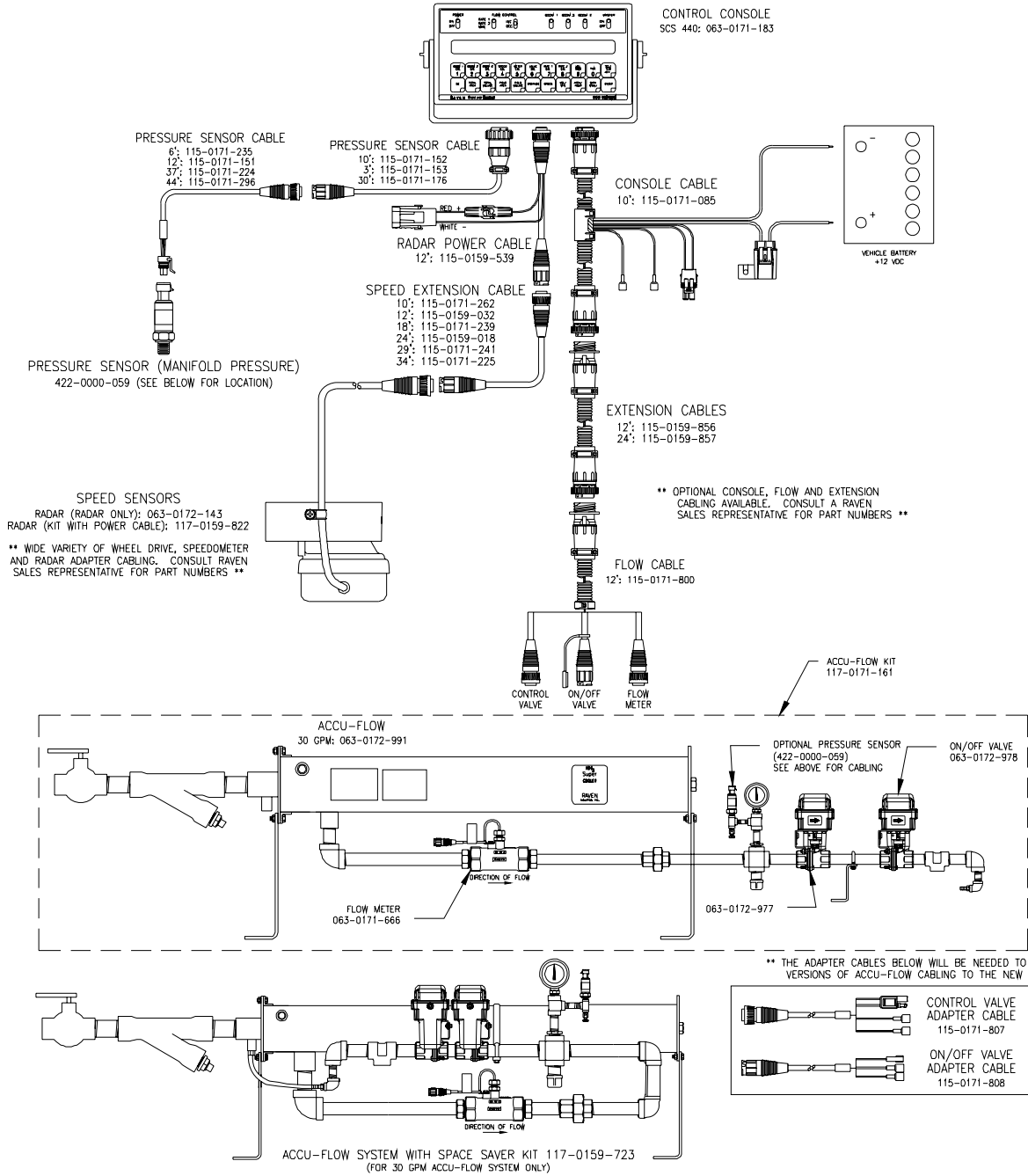

### SCS 440 WITH ACCUFLOW, FAST VALVE SYSTEM

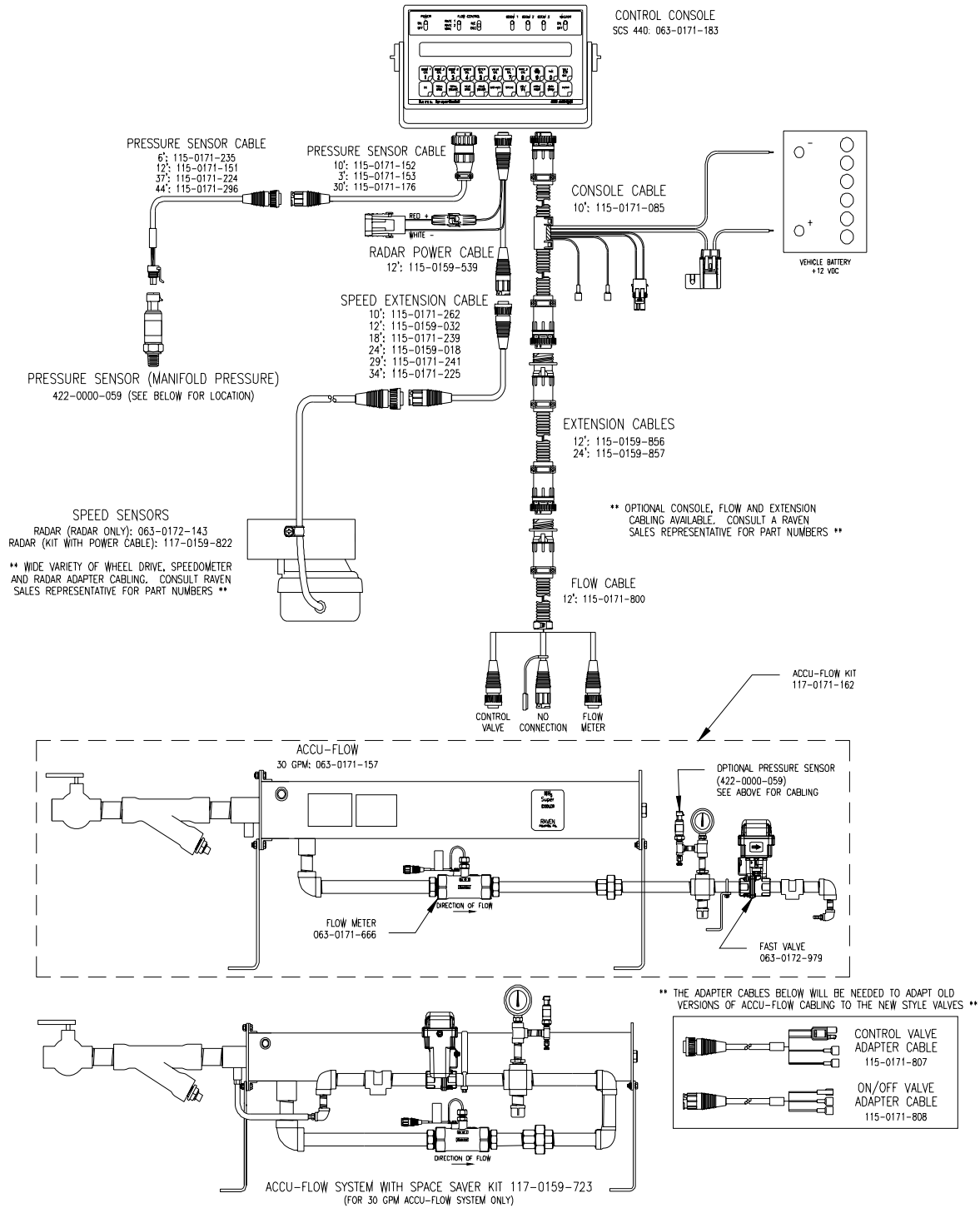



SCS 440 WITH ACCUFLOW, 2 VALVE SYSTEM WITH 2 SECTION VALVES

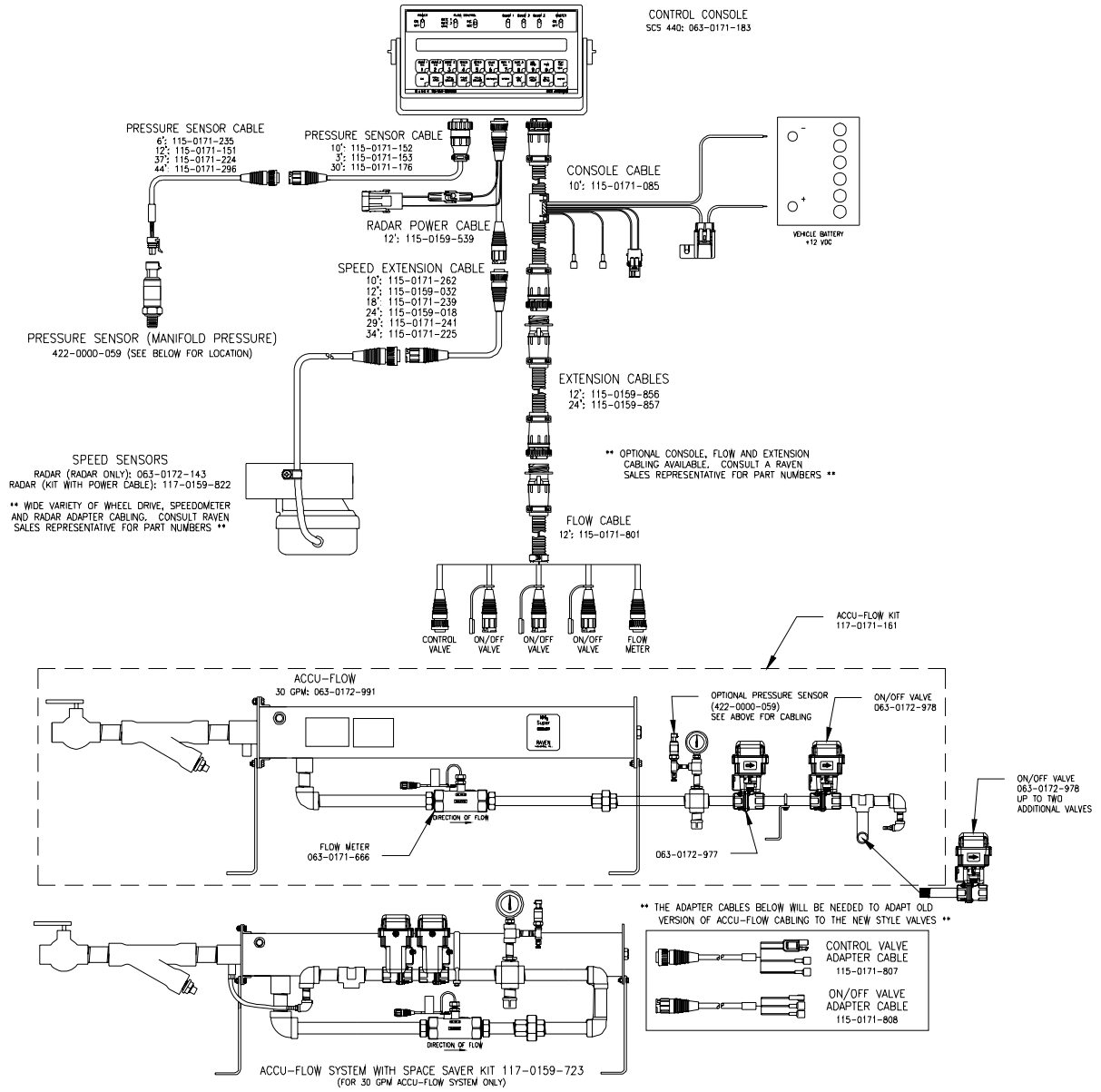

### SCS 440 WITH ACCUFLOW, FAST VALVE SYSTEM WITH 3 SECTION VALVES

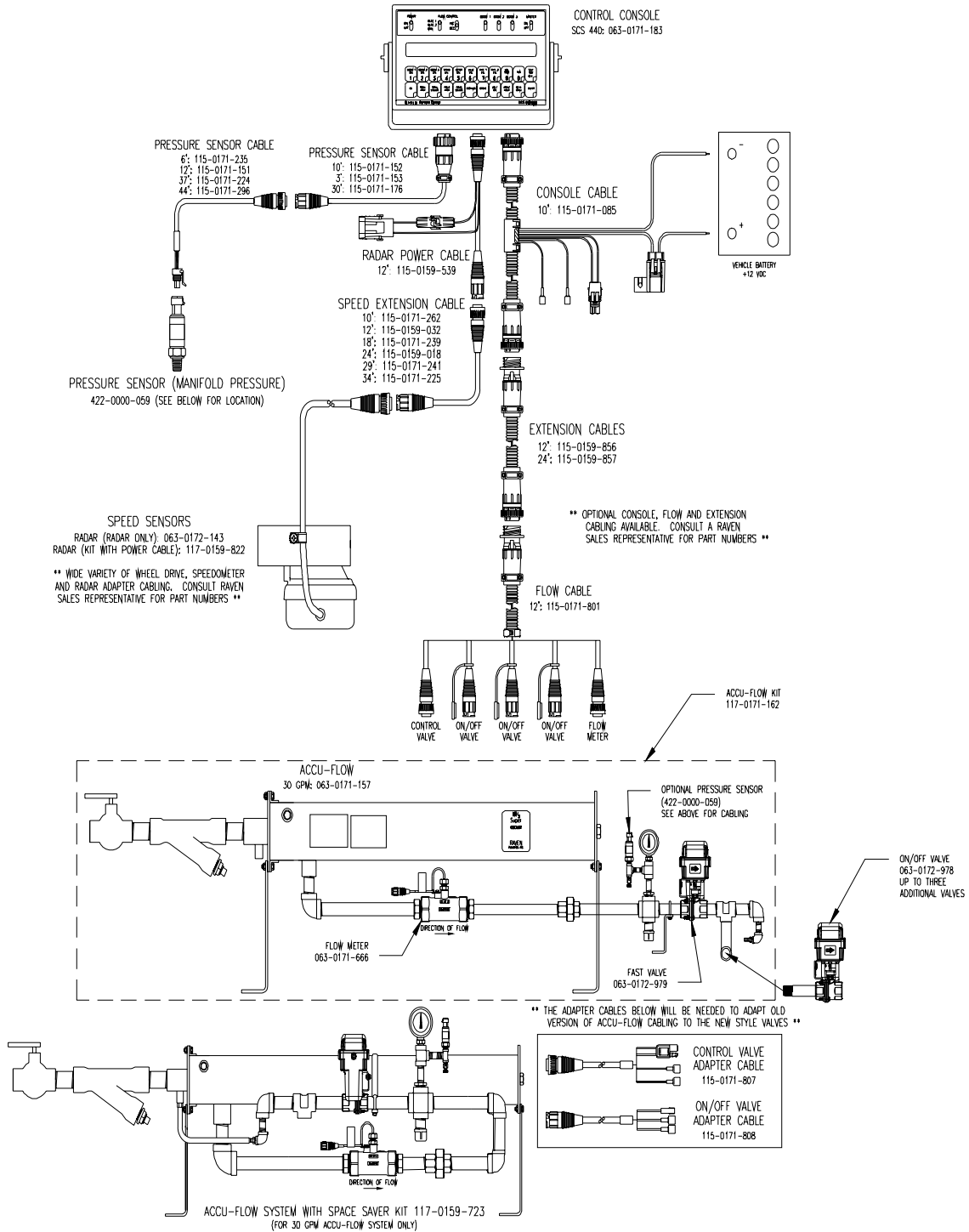

## SCS 4400 WITH ACCUFLOW, 2 VALVE SYSTEM

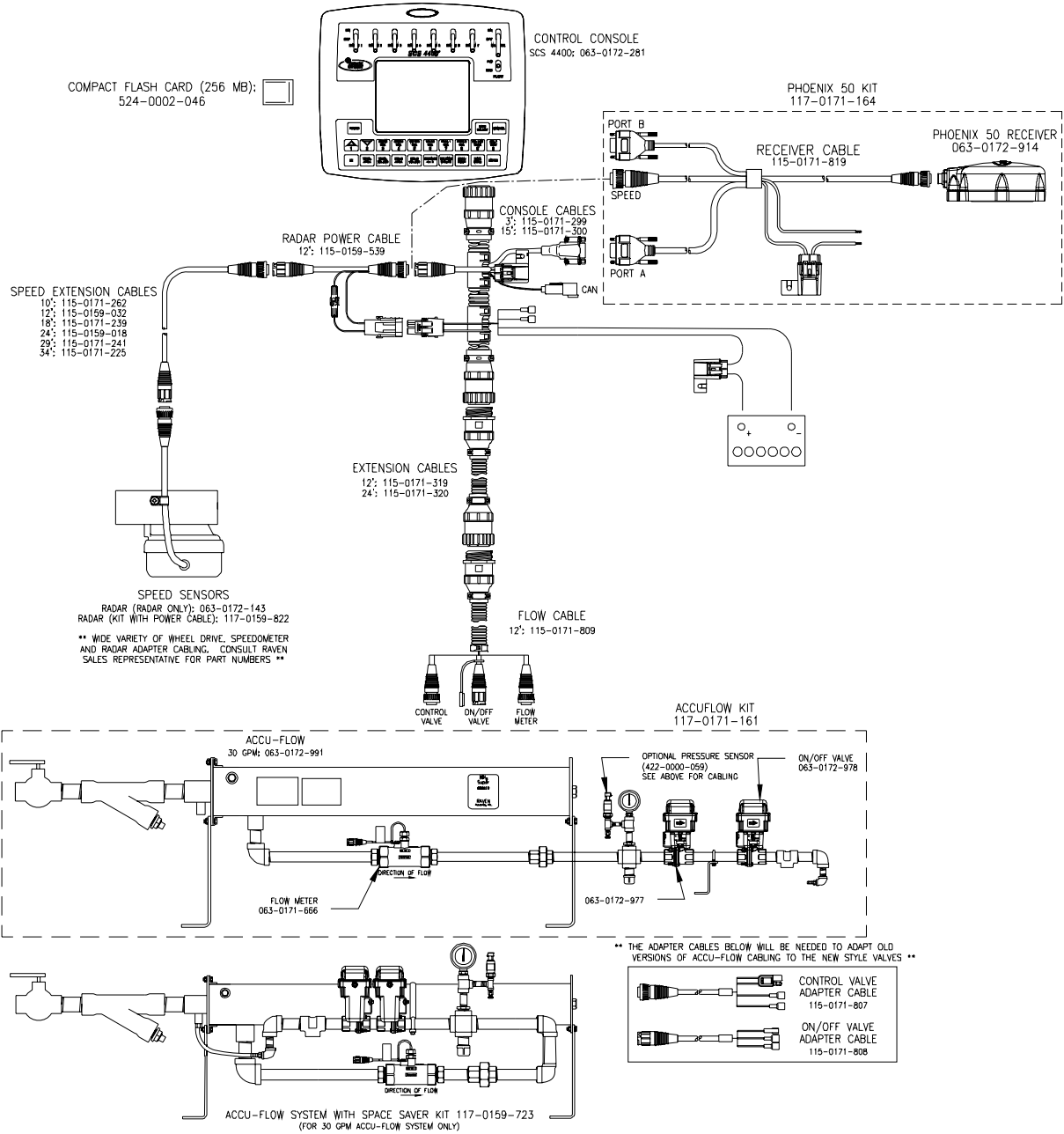

# SCS 4400 WITH ACCUFLOW, FAST VALVE SYSTEM

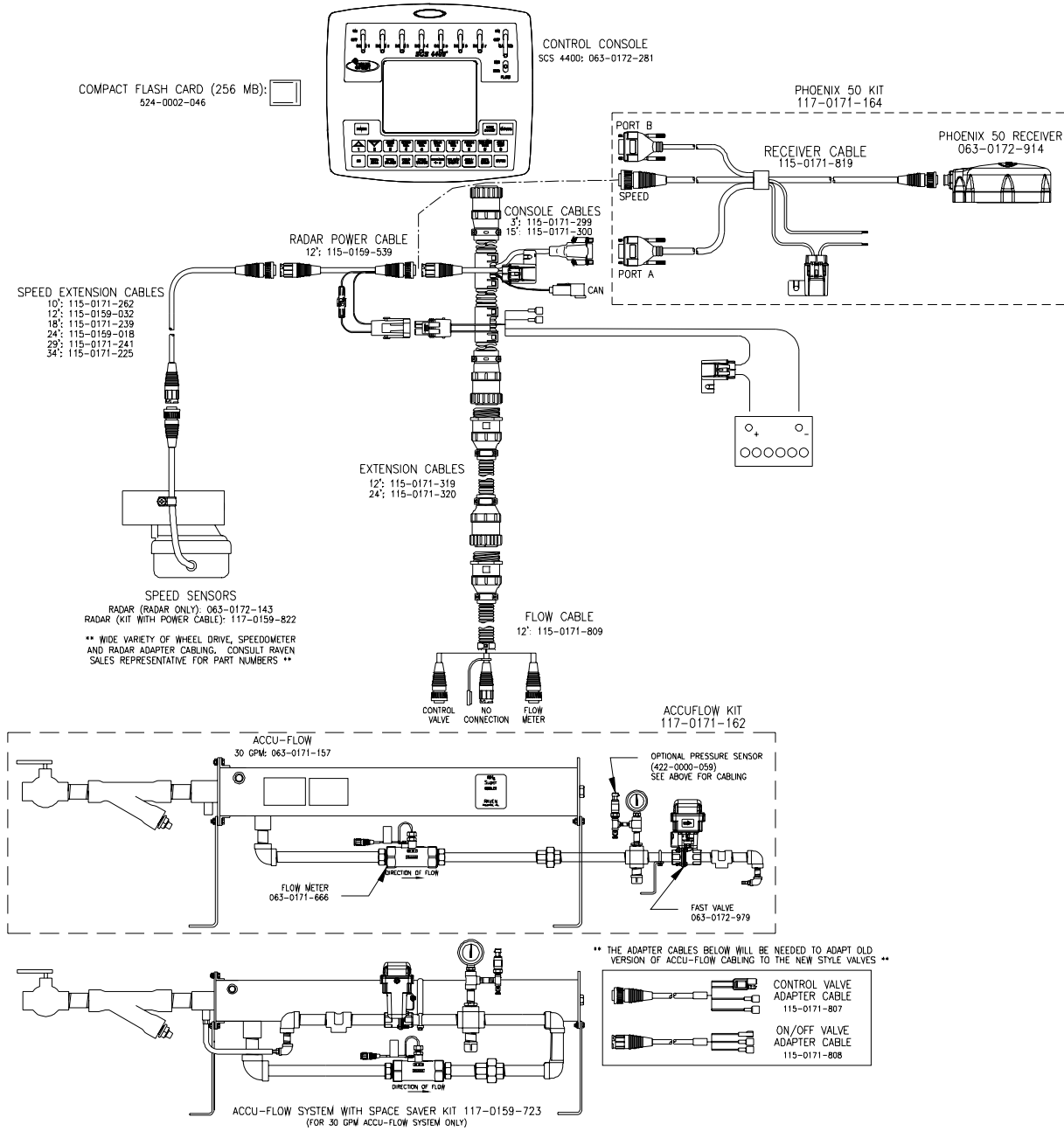

# SCS 4400 WITH ACCUFLOW, 2 VALVE SYSTEM WITH 2 SECTION VALVES

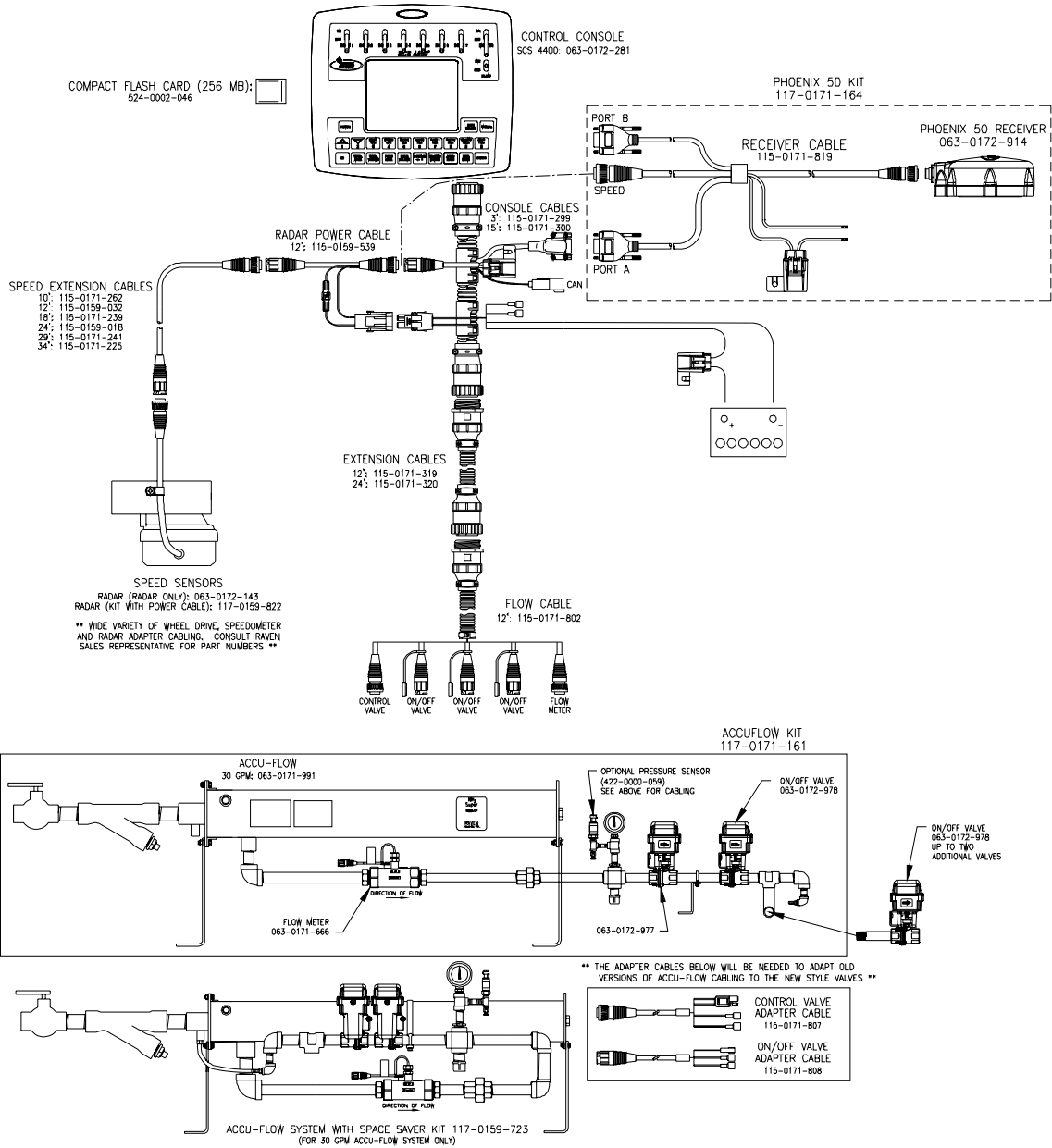

# SCS 4400 WITH ACCUFLOW, FAST VALVE SYSTEM WITH 3 SECTION VALVES

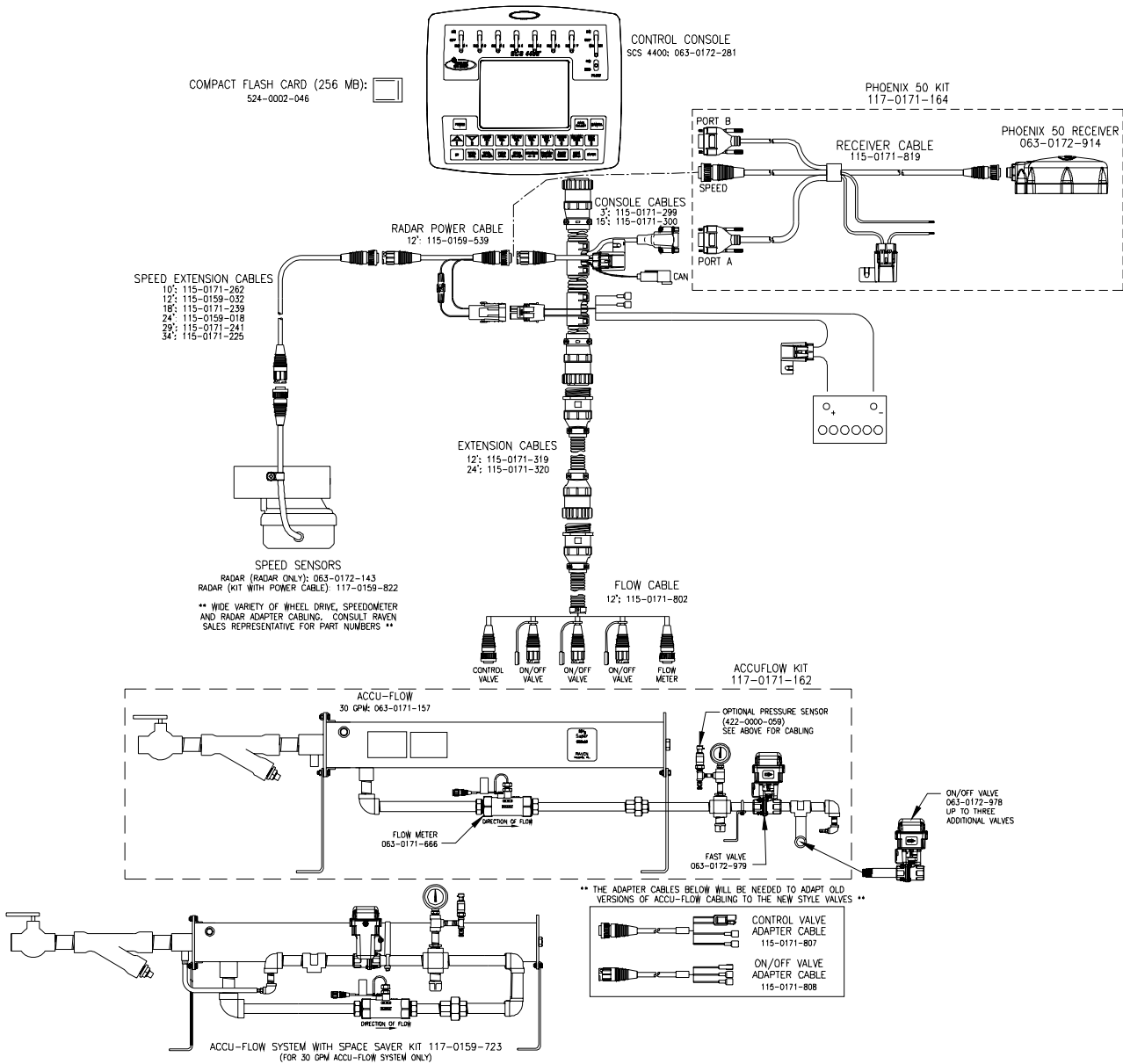



## **RAVEN INDUSTRIES**

### **LIMITED WARRANTY**

#### **WHAT IS COVERED?**

This warranty covers all defects in workmanship or materials in your Raven Flow Control Product under normal use, maintenance, and service.

#### **HOW LONG IS THE COVERAGE PERIOD?**

This warranty coverage runs for 12 months from the purchase date of your Raven Flow Control Product. This warranty coverage applies only to the original owner and is not transferable.

#### **HOW CAN YOU GET SERVICE?**

Bring the defective part, and proof of date of purchase, to your local dealer. If your dealer agrees with the warranty claim, he will send the part, and proof of purchase to his distributor or to Raven for final approval.

#### **WHAT WILL RAVEN INDUSTRIES DO?**

When our inspection proves the warranty claim, we will, at our option, repair or replace the defective part and pay for return freight.

#### **WHAT DOES THIS WARRANTY NOT COVER?**

Raven Industries will not assume any expense or liability for repairs made outside our plant without written consent. We are not responsible for damage to any associated equipment or product and will not be liable for loss of profit or other special damages. The obligation of this warranty is in lieu of all other warranties, expressed or implied, and no person is authorized to assume for us any liability. Damages caused by normal wear and tear, misuse, abuse, neglect, accident, or improper installation and maintenance are not covered by this warranty.



Raven Industries  
Flow Controls Division  
P.O. Box 5107  
Sioux Falls, SD 57117-5107

Toll Free (U.S. and Canada): 800-243-5435  
or Outside the U.S.: +1 605-575-0722

Fax 605-331-0426

[www.ravenprecision.com](http://www.ravenprecision.com)  
[fcinfo@ravenind.com](mailto:fcinfo@ravenind.com)