

THE *Right* PRODUCTS  
PEOPLE  
CHOICE

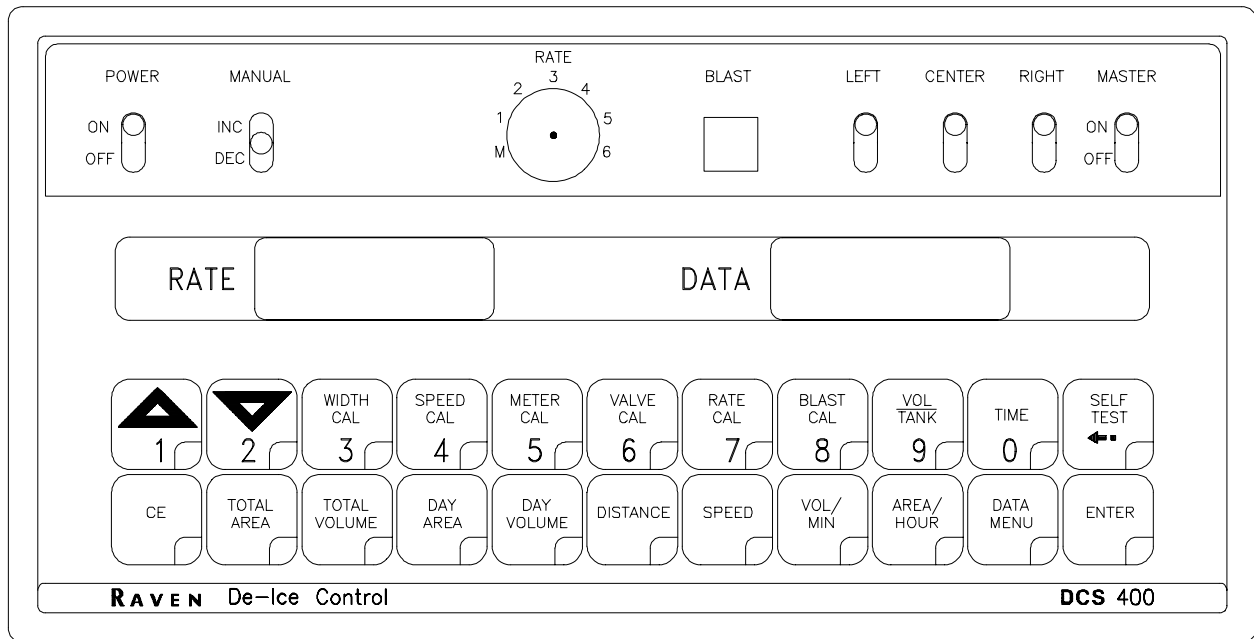

# DCS 400



# INSTALLATION AND SERVICE MANUAL

N O T I C E

The use of the suspension type fertilizers and lime slurries will significantly reduce the life of the plastic parts in the Flow Meter and motorized Control Valve. Check the rotor and inlet hub assembly in the Flow Meter frequently for worn parts. Excessive wear can affect accuracy.

Do not attempt to modify or lengthen any of the three-wire Speed Sensor or Flow Meter cables. Extension cables are available from your dealer.

W A R N I N G

Disconnect console before jump starting, charging battery, or welding on equipment.

THIS CARD IS PROVIDED FOR YOUR CONVENIENCE. PENCIL IN YOUR CALIBRATION NUMBERS FOR FUTURE REFERENCE.  
 CUT ON DOTTED LINE, FOLD, AND INSERT INTO PLASTIC ENVELOPE.

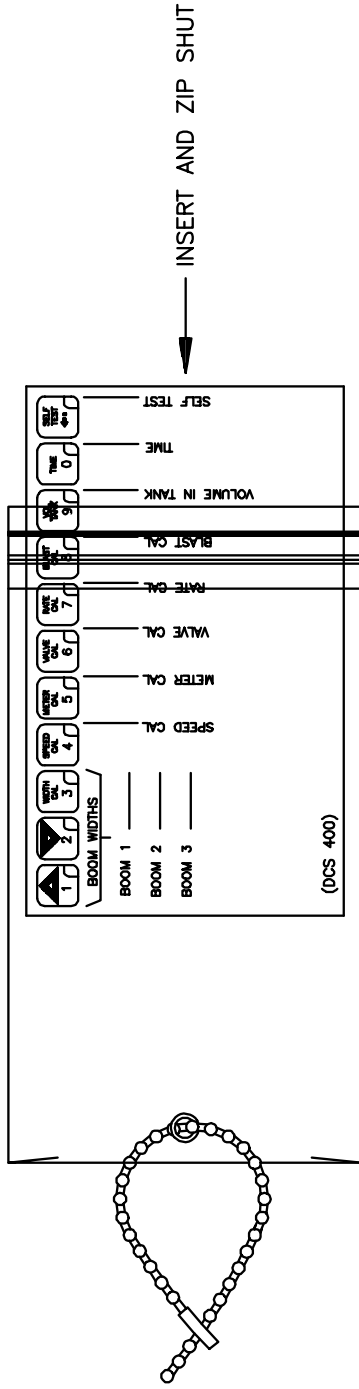

FOLD LINE

CUT ON DOTTED LINE

**WARNING:** DISCONNECT CONSOLE BEFORE JUMP STARTING,  
 CHARGING BATTERY, OR WELDING ON EQUIPMENT.

DATA ENTRY EXAMPLE: TO ENTER VALVE CAL.

1. PRESS VALVE CAL KEY.
2. PRESS ENTER KEY.
3. PRESS KEYS REQUIRED, TO ENTER PROPER NUMBER.

(EXAMPLE: KEYS FOR 2123)

4. PRESS ENTER KEY AGAIN.

1	2	3	4	5	6	7	8	9	0	←	•••
▲	▼	W	S	M	V	R	B	VOL TANK	TIME	SELF TEST	•••
BOOM WIDTHS			SPEED CAL	METER CAL	VALVE CAL	RATE CAL	BLAST CAL	VOLUME IN TANK	TIME	SELF TEST	•••
BOOM 1 _____	BOOM 2 _____	BOOM 3 _____									

(DCS 400)

# TABLE OF CONTENTS

SYMBOL DEFINITION .....	2
INTRODUCTION .....	3
INSTALLATION.....	4
1. INSTALLATION OF RAVEN RADAR .....	4
2. MOUNTING THE FLOW METER .....	5
3. MOUNTING THE CONTROL VALVE .....	5
4. MOUNTING THE CONSOLE AND CABLING .....	6
BATTERY CONNECTIONS .....	7
CONSOLE FEATURES .....	8
CONSOLE CALIBRATION .....	9
1. CALCULATING "WIDTH CAL" .....	9
2. CALCULATING "SPEED CAL" .....	9
3. CALCULATING "METER CAL" .....	10
4. CALCULATING "VALVE CAL" .....	10
5. CALCULATING "RATE 1-RATE 6 CAL" .....	11
6. CALCULATING "BLAST CAL" .....	12
CONSOLE PROGRAMMING.....	13
1. INITIAL CONSOLE PROGRAMMING .....	14
2. OTHER DISPLAY FEATURES .....	16
3. SELF TEST FEATURE .....	17
4. SEQUENCE TO ACTIVATE DATA-LOCK .....	17
5. SEQUENCE TO CHANGE DATA-LOCK .....	17
6. ENTER MODE SEQUENCE WITH ACTIVATED DATA-LOCK .....	17
7. POWER DOWN DELAY TIME FEATURE .....	18
8. CONSOLE ALARM FEATURE .....	18
9. DISPLAYING AND PROGRAMMING AUXILARY FEATURES .....	18
10. CONTROL VALVE DELAY .....	19
11. DECIMAL SHIFT .....	20
INITIAL SYSTEM SET-UP.....	21
INITIAL SYSTEM ROAD TEST .....	22
PREVENTIVE MAINTENANCE .....	22
TROUBLESHOOTING GUIDE.....	23

---

## APPENDIXES

---

1. SPEEDOMETER SPEED SENSOR INSTALLATION AND CALIBRATION .....	26
2. PROCEDURE TO TEST SPEED SENSOR EXTENSION CABLES .....	28
3. PROCEDURE TO TEST FLOW METER CABLES .....	29
4. FLOW METER MAINTENANCE AND ADJUSTMENT PROCEDURE .....	30
5. PROCEDURE TO RE-CALIBRATE FLOW METER .....	31
6. REMOTE SWITCH OPTION .....	32
7. SERIAL INTERFACE.....	33

# SYMBOL DEFINITION

GPM	- Gallons per minute	gal	- Gallons
lit/min	- Liters per minute	lit	- Liters
dl/min	- Deciliter per minute	MPH	- Miles per hour
PSI	- Pounds per square inch	km	- Kilometers
kPa	- Kilopascal	km/h	- Kilometers per hour
GPK	- Gallons per 1,000 sq. ft.	US	- Volume per lane mile
mm	- Millimeters	SI	- Volume per lane kilometer
cm	- Centimeters	TU	- Volume per 1,000 sq. ft.
dm	- Decimeters	[]	- Metric numbers
m	- Meter	{}	- 1,000 sq. ft. numbers

## METER CAL CONVERSIONS

To convert the METER CAL number simply divide the original number (number printed on Flow Meter label) by the desired conversion factor.

### FOR EXAMPLE:

$$\frac{\text{Original METER CAL No.}}{128} = \text{METER CAL No. for displays in Fluid Ounces}$$

$$\frac{\text{Original METER CAL No.}}{3.785} = \text{METER CAL No. for displays in Liters}$$

$$\frac{\text{Original METER CAL No.}}{\text{Weight of one gallon}} = \text{METER CAL No. for displays in Pounds}$$

## LIQUID CONVERSIONS

U.S. Gallons x 128 = Fluid Ounces  
U.S. Gallons x 3.785 = Liters  
U.S. Gallons x 0.83267 = Imperial Gallons  
U.S. Gallons x 8.34 = Pounds (Water)

## LENGTH

1 millimeter (mm) = 0.039 inch  
1 centimeter (cm) = 0.393 inch  
1 meter (m) = 3.281 feet  
1 kilometer (km) = 0.621 mile  
1 inch = 25.4 millimeters; 2.54 centimeters  
1 mile = 1.609 kilometers  
1 mile = 5280 feet

## PRESSURE

1 psi = 6.89 kPa  
1 kPa = 0.145 psi

## AREA

1 square meter = 10.764 square feet  
1 hectare (ha) = 2.471 acres; 10,000 square meters  
1 acre = 0.405 hectare; 43,560 square feet  
1 square mile = 640 acres; 258.9 hectares

# INTRODUCTION

The Raven DCS 400 (DE-ICE CONTROL SYSTEM) is designed to improve the uniformity of liquid de-ice applications. Its performance relies on the installation and preventive maintenance of the complete system. It is important that this Installation and Service Manual be reviewed thoroughly before operating the system. This manual provides a simple step-by-step procedure for installing and operating.

The DCS 400 system consists of a computer-based control Console, a Speed Sensor, a turbine type Flow Meter and a motorized Control Valve. The Console mounts directly in the cab of the vehicle for easy operator use. The Speed Sensor is mounted on the vehicle. (Other Speedometer Speed Sensors also available). The motorized Control Valve and Flow Meter mount to the vehicle framework. Appropriate cabling is furnished for field installation.

The operator sets the target volume per area to be applied and the DCS 400 automatically maintains the flow regardless of vehicle speed. A manual override switch allows the operator to manually control flow for system check-out and spot application. Actual volume per area being applied is displayed at all times. The DCS 400 additionally functions as an area or distance monitor, speed monitor, and volume totalizer.

# INSTALLATION

## 1. INSTALLATION OF RAVEN RADAR

For mounting the radar, the following guidelines will assure proper installation: It is suggested that a large heavy mounting bracket, (P/N 107-0159-693) be attached to the vehicle frame for mounting the radar. (See Appendix 1 for Speedometer Speed Sensor installation instructions).

- 1) Park vehicle on level surface.
- 2) Select mounting site by considering the following:
  - a) The line of sight from the lens to the ground must not be obstructed by structures or tires. Obstructions must not come closer than 20 inches to the bottom of the Radar. See Figures 1 and 2.
  - b) The radar lens must be parallel to the ground from front to back. Radar can be tilted out 0-15 degrees to provide more clearance and miss obstructions. See Figure 2.
  - c) The radar should be mounted so that the **length** of the radar is **parallel** with direction of vehicle travel.
- 3) Use carpenters level to verify that mounting bracket is parallel to the ground.
- 4) Bolt mounting bracket to implement.
- 5) Bolt radar to mounting bracket using mounting hardware. See Figure 3.
- 6) Connect radar with Radar Interface Cable (P/N 115-0159-539), to the DCS 400 Console. The Red wire should be connected to the Orange cable wire. The White wire should be connected to the White cable wire. (See Figure 5 on page 7).

**CAUTION:** The connection of the radar power in reverse polarity could result in damage to the radar.

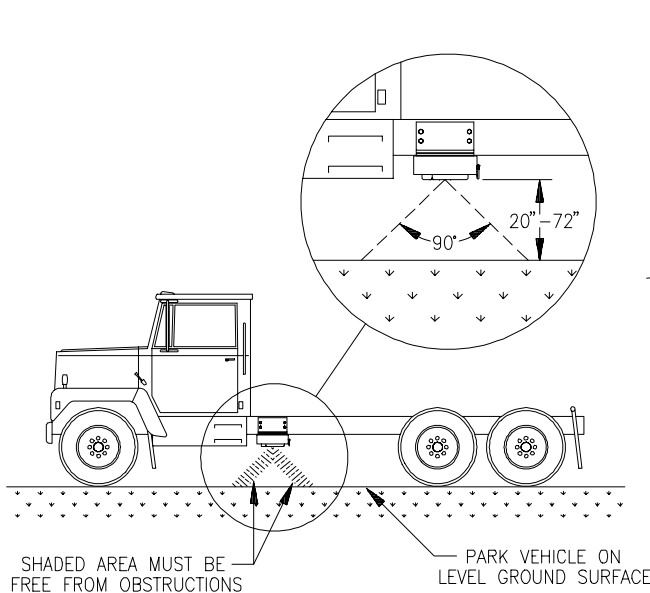

FIGURE 1

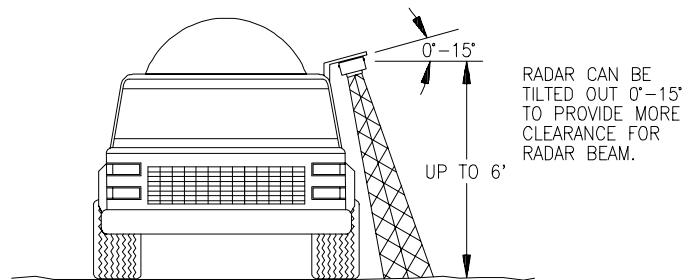

FIGURE 2

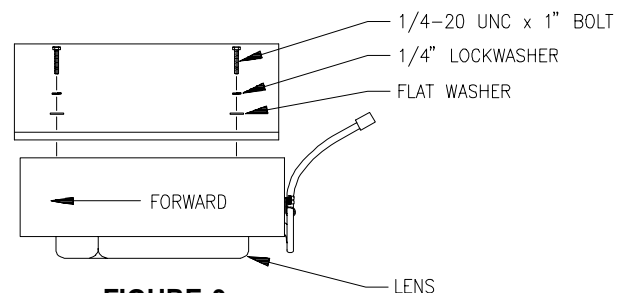

FIGURE 3

## 2. MOUNTING THE FLOW METER

- 1) Mount Flow Meter horizontally using bracket per Figure 4. All flow through Flow Meter must go to booms only, i.e., no return line to tank or pump after Flow Meter.
- 2) For best results, allow a minimum length of 7 1/2 inches of straight hose on inlet of Flow Meter. Bend radius of hose on outlet of Flow Meter should be gradual.
- 3) Flow must be in direction of arrow on Flow Meter.

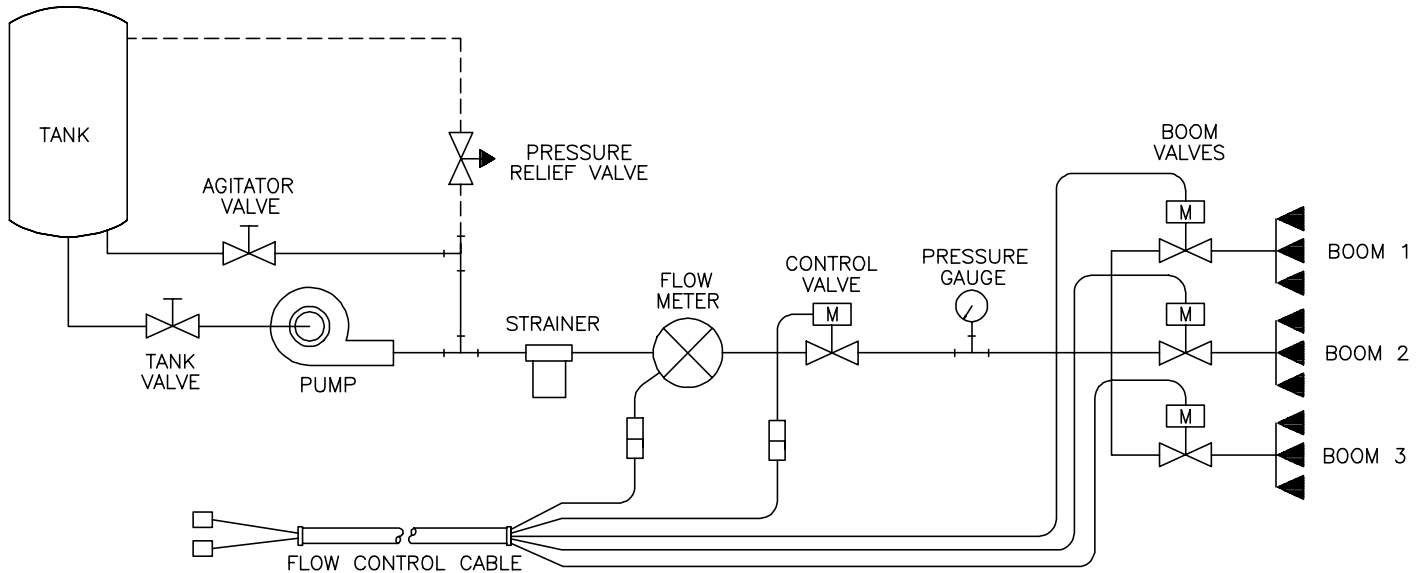

FIGURE 4

**NOTE:** It is essential, when using suspensions, that the system be thoroughly rinsed out each day after use.

## 3. MOUNTING THE CONTROL VALVE

- 1) Mount the motorized Control Valve in the main hose line between the Flow Meter and the booms valves, with motor in the upright position.
- 2) Connect the Flow Control Cable connectors to Flow Meter, Motorized Control Valve, and boom valves. (Black wire to left boom valve, Brown to center boom valve, and Blue to right boom valve).



## 4. MOUNTING THE CONSOLE AND CABLING

- 1) Mount the Console to a secure support inside the cab of the vehicle.
- 2) Connect the Console Control Cable to the plug in the back of the Console. (Reference Figure 5). Route the Console Control Cable out of the vehicle cab and terminate. (Flow Meter extension cables are available from your Dealer).

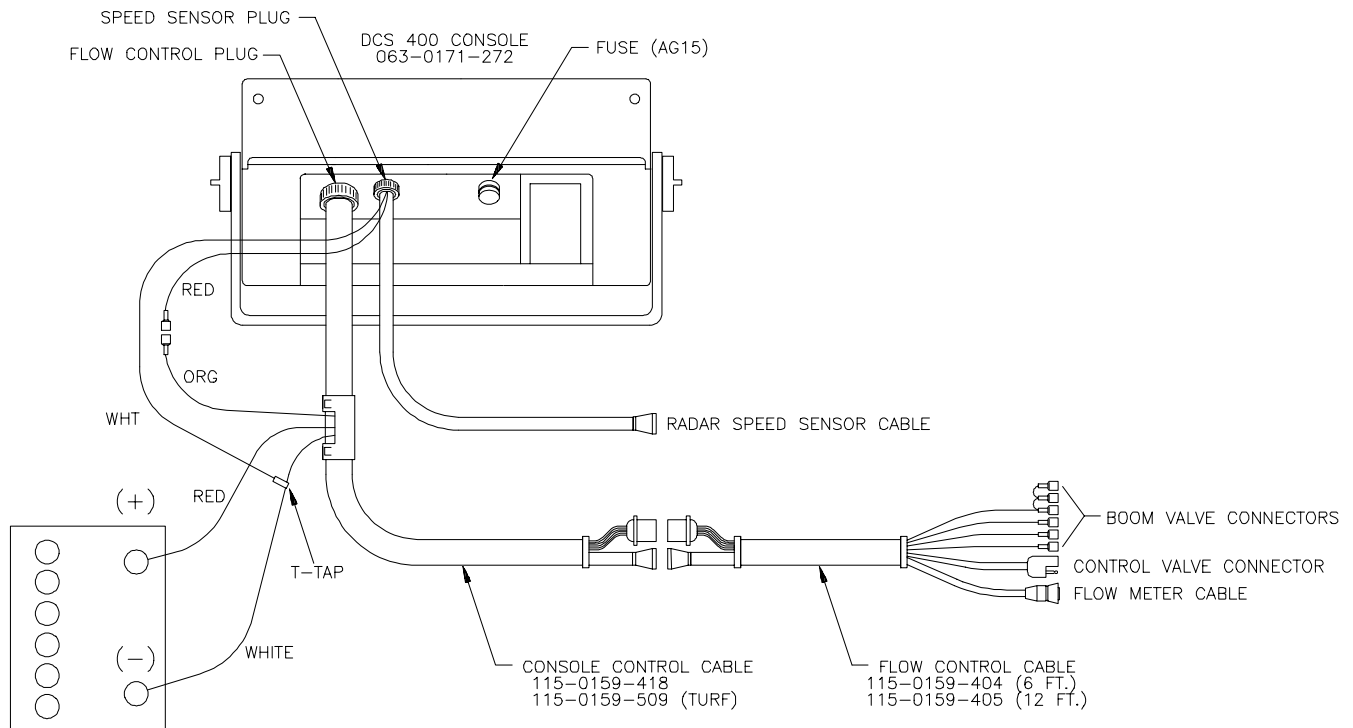

FIGURE 5

- 3) Turn POWER ON/OFF switch OFF and route the Red and White battery wires to a 12-volt battery. Attach the White battery wires to the **NEGATIVE** (-) terminal and the Red battery wire directly to the **POSITIVE** (+) battery terminal. (See Figure 6 on page 8). (**DO NOT CONNECT RED AND WHITE WIRES TO THE STARTER**). Secure the battery wires with plastic cable ties. **DO NOT** tie the battery wires close to the existing battery leads or any other electrical wiring.
- 4) Connect the Speed Sensor to the plug in the back of the Console.
- 5) Secure and tie the Speed Sensor Cable and the Console Control Cable with plastic cable ties.
- 6) Initial installation of the system is now complete.

# BATTERY CONNECTIONS

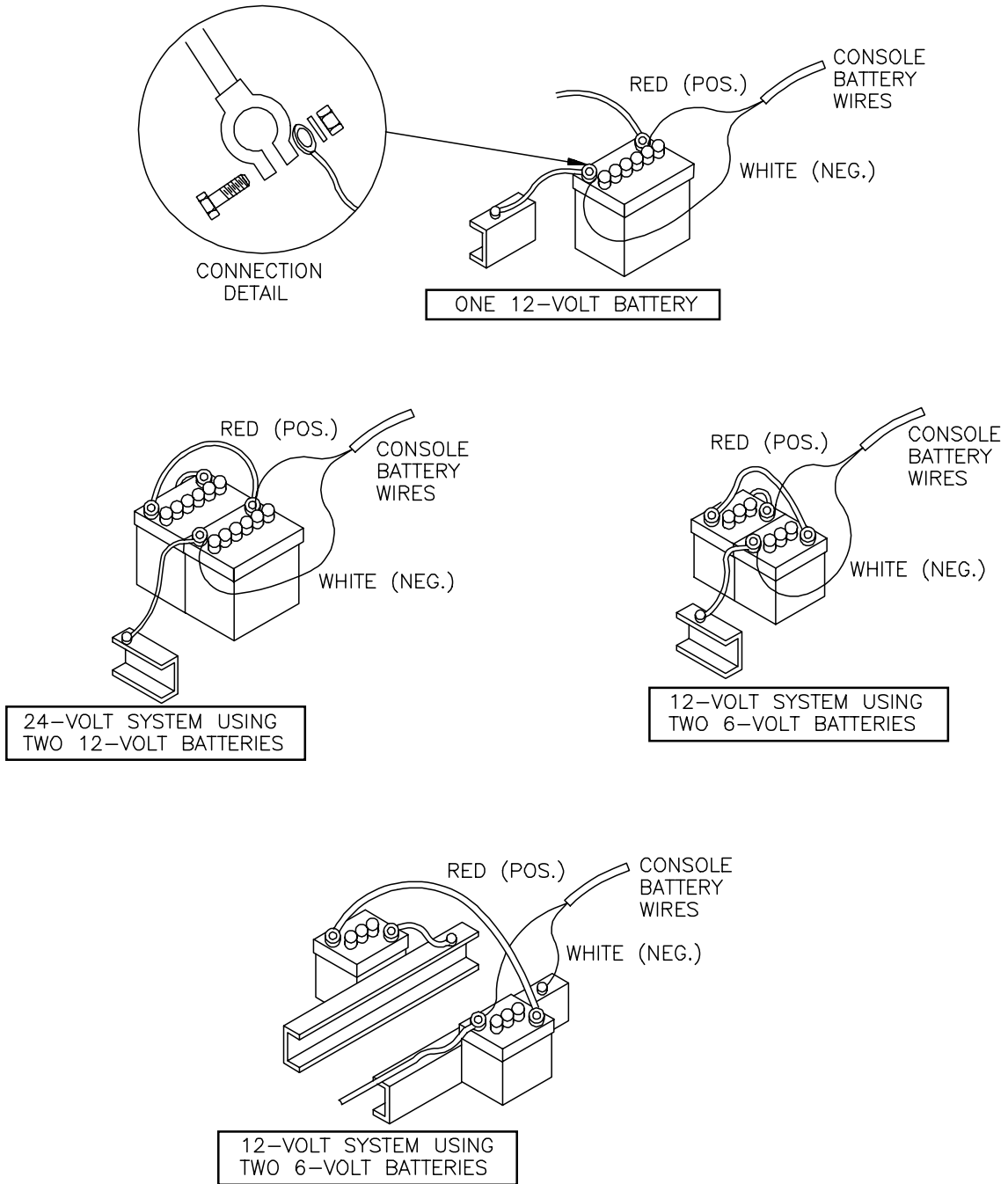

FIGURE 6

# CONSOLE FEATURES

**IMPORTANT:** This Console requires selection of **US** (lane miles), **SI** [lane km], or **TU** {1,000 sq. ft.} area; and **C-Sd** (Standard Valve), **C-F** (Fast Valve), or **C-FC** (Fast Close Valve); and **SP1** (wheel drive, etc.) or **SP2** (radar) speed sensor.



Console Revision can be determined by the letter stamped in REV box on label.

Console Program can be determined by the letter stamped in PGM box on label.

**POWER** -Turns Console power ON or OFF. Turning Console OFF does not affect the data stored in the computer.

Manual override control provides capability for spot spraying.

**BLAST** button provides change in rate to volume per minute for a selected amount of time.

Select manual or fully automatic control. Can automatically control 6 rates.

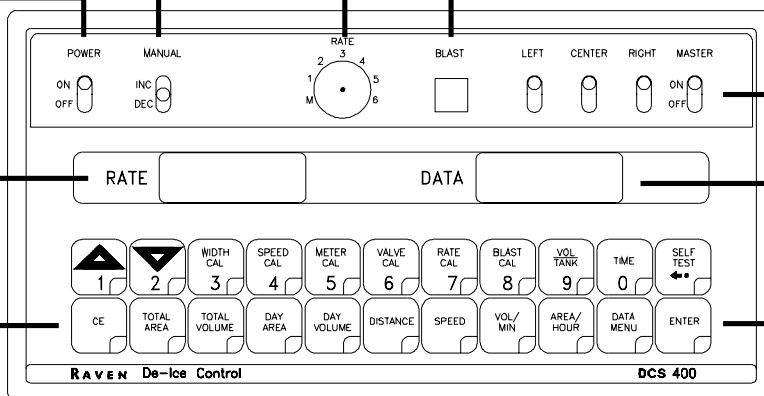

**CE** -Use like you do the CE key on a calculator. This key is also used to select the features listed in IMPORTANT box above.

Displays operating rate of application.

**ENTER** -Used only to enter data into the Console.

Displays function and calibration data.

Booms can be controlled individually, or all at once with MASTER ON/OFF switch.

**CALIBRATION KEYS** -- Used to enter data into the Console to calibrate the system.

**WIDTH CAL** -- Length of BOOM and Lane Width. Select by using up and down arrows.

**SPEED CAL** -- Determined by Speed Sensor  
**METER CAL** -- Flow Meter Calibration Number  
**VALVE CAL** -- Valve Response Time  
**RATE CAL** -- Target Application Rate, Rate 1-6

**BLAST CAL** -- Target Application Blast Rate and Blast Time

**SELF TEST** -- Simulates Vehicle Speed

**FUNCTION KEYS** -- Used to Display Data

**TOTAL AREA** -- Total Area Applied

**TOTAL VOLUME** -- Total Volume Applied

**DAY AREA** -- Day Area Applied

**DAY VOLUME** -- Day Volume Applied

**DISTANCE** -- Distance Traveled

**SPEED** -- Speed of Vehicle

**VOLUME/TANK** -- Volume Remaining in Carrier Tank

**TIME** -- 24 Hour Clock (Military Time)

**VOL/MIN** -- Volume per Minute

**AREA/HOUR** -- Area per Hour

**DATA/MENU** -- Print Data

# CONSOLE CALIBRATION

## 1. CALCULATING "WIDTH CAL"

Calculate the width of each boom in inches [cm] by multiplying the number of tips times the spacing. Write these boom widths down for future reference when programming the Console.

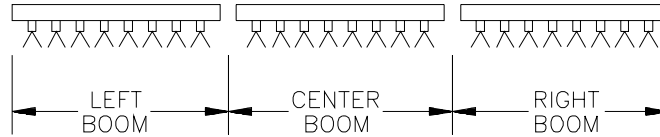

FIGURE 7

## 2. CALCULATING "SPEED CAL"

Initial SPEED CAL is 598 [152]. Complete Steps 1 thru 6 to refine this number **AFTER** INITIAL CONSOLE PROGRAMMING, on page 15, has been completed.

1) Set POWER switches to ON, all other switches to OFF.

2) Enter "0" in key labelled:



3) Drive 1 mile [1 kilometer]. To achieve the most accurate calibration, accelerate and decelerate slowly. (**CAUTION:** Do not use vehicle odometer to determine distance. Use section lines or highway markers).

4) Read DISTANCE by depressing key labelled:



Distance should read a value of approximately 5280 [1000]. If it reads between 5260-5300 [990-1010], the SPEED CAL for the vehicle is 598 [152]. If the DISTANCE display reads any other value, perform the following calculation:

**EXAMPLE:** Assume DISTANCE reads 5000 [980].

$$\text{Corrected SPEED CAL} = \frac{\text{Old SPEED CAL} \times 5280}{\text{DISTANCE}}$$

$$\begin{aligned} \text{ENGLISH UNITS:} \\ &= \frac{598 \times 5280}{5000} = 631.5 \end{aligned}$$

$$\begin{aligned} \text{METRIC UNITS:} \\ &= \frac{[152] \times [1000]}{[980]} = [155] \end{aligned}$$

5) The number to enter for SPEED CAL is 631 [155].

6) Recheck the new SPEED CAL derived in Step 5 by repeating Steps 2 thru 5.

### 3. CALCULATING "METER CAL"

The Flow Meter calibration number is stamped on the tag attached to each Flow Meter. Write down this number for future reference when programming the Console computer.

To convert original METER CAL from gallons to desired units of measure (oz, lbs, or liters per area), see METER CAL CONVERSIONS on page 3. Write down this calibration number for future reference when programming the Console.

### 4. CALCULATING "VALVE CAL"

1) The initial Control Valve calibration number is 2123 for C-Sd, 743 for C-F or C-FC. After operating the system, you may desire to refine this number. See definitions below.

For **STANDARD VALVE** (C-Sd):

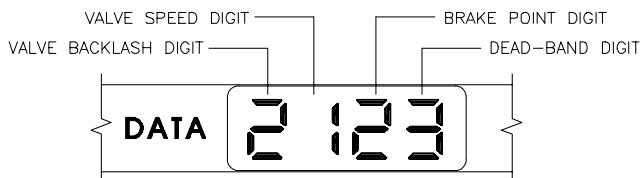

For **FAST VALVE** (C-F or C-FC):

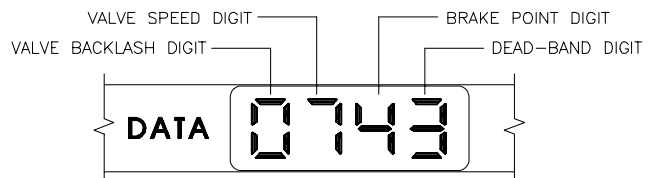

Valve Backlash Digit -- Controls the time of the first correction pulse after a change in correction direction is detected. (INC to DEC -or- DEC to INC).

Range: 1 to 9 1-Short Pulse, 9-Long Pulse

Valve Speed Digit -- Controls response time of Control Valve motor. **CAUTION:** Running the Control Valve too fast will cause the system to oscillate.

C-Sd Valve Control	Range: 1 to 9	1-Slow, 9-Fast
C-F or C-FC Valve Control	Range: 0 to 9	9-Slow, 0-Fast

Brake Point Digit -- Sets the percent away from target rate at which the Control Valve motor begins braking, so as not to overshoot the desired rate.

Range: 0 to 9 0 = 5%, 1 = 10%, 9 = 90%

Dead-Band Digit -- Allowable difference between target and actual application rate, where rate correction is not performed.

Range: 1 to 9 1 = 1%, 9 = 9%

## 5. CALCULATING "RATE 1 - RATE 6 CAL"

Determine the application rate at which your chemical should be applied. Consult with your Dealer to ensure your spray nozzles are capable of applying at this rate.

In determining which spray nozzles to use with your sprayer, you must know:

- |                                 |       |                             |
|---------------------------------|-------|-----------------------------|
| 1) Nominal Application Pressure | _____ | PSI [kpa]                   |
| 2) Target Application Rate      | _____ | gal/lane mile [lit/lane km] |
| 3) Target Speed                 | _____ | MPH [km/h]                  |
| 4) Nozzle Spacing               | _____ | inches [cm]                 |
| 5) Lane Width                   | _____ | feet [meters]               |

From this information you can then calculate the volume per minute per nozzle as follows:

$$\text{GPM} = \frac{(\text{gal/lane mile}) \times \text{MPH} \times \text{inches}}{(720 \times \text{lane width})}$$

If Lane Width = 0

$$\text{GPM} = \frac{(\text{gal/mile}) \times \text{MPH}}{60 \times (\# \text{ of tips})}$$

$$\text{lit/min} = \frac{(\text{lit/lane km}) \times (\text{km/hr}) \times \text{cm}}{(6000 \times \text{Lane Width})}$$

If Lane Width = 0

$$\text{lit/min} = \frac{(\text{lit/km}) \times (\text{km/hr})}{60 \times (\# \text{ of tips})}$$

Turf

$$\text{GPM} = \frac{\text{GPK} \times \text{MPH} \times \text{inches}}{137}$$

- EXAMPLE:**
- |                            |   |  |
|----------------------------|---|--|
| 1) Application Pressure    | = | <u>30</u> PSI [200 kPa]                  |
| 2) Target Application Rate | = | <u>20</u> gal/lane mile [40 lit/lane km] |
| 3) Target Speed            | = | <u>5.2</u> MPH [10 km/h]                 |
| 4) Nozzle Spacing          | = | <u>20</u> inches [50 cm]                 |
| 5) Lane Width              | = | <u>8</u> feet [2 m]                      |

**US UNITS**       $\text{GPM} = \frac{20 \text{ gal/lane mile} \times 5.2 \text{ MPH} \times 20 \text{ inches}}{720 \times 8 \text{ ft}} = .36$

**SI UNITS**       $[\text{lit/min}] = \frac{40 \text{ lit/lane km} \times 10 \text{ km/h} \times 50 \text{ cm}}{6000 \times 2 \text{ m}} = 1.67$

**Turf**       $\text{GPM} = \frac{.46 \text{ GPK} \times 5.2 \text{ MPH} \times 20 \text{ inches}}{137} = .35$

Using CAPACITY = .35 GPM [1.67 lit/min] and pressure = 30 PSI [200 kPa], you would select tip number XR8004 from the chart on next page, since it comes closest to providing the desired output.

TIP COLOR	TIP NO.		LIQUID PRESSURE IN PSI	CAPACITY 1 NOZZLE IN GPM	CAPACITY 1 NOZZLE IN OZ/MIN	GALLONS PER ACRE 20" SPACING			
	80 DEG.	110 DEG.				5 MPH	6 MPH	7 MPH	8 MPH
YELLOW	XR8002	XR11002	15	.12	15	7.3	6.1	5.2	4.5
			20	.14	18	8.4	7.0	6.0	5.3
			30	.17	22	10.3	8.6	7.4	6.4
			40	.20	26	11.9	9.9	8.5	7.4
			60	.25	32	14.6	12.1	10.4	9.1
BLUE	XR8003	XR11003	15	.18	23	10.9	9.1	7.8	6.8
			20	.21	27	12.6	10.5	9.0	7.9
			30	.26	33	15.4	12.9	11.0	9.7
			40	.30	38	17.8	14.9	12.7	11.1
			60	.37	47	22.0	18.2	15.6	13.6
RED	XR8004	XR11004	15	.24	31	14.5	12.1	10.4	9.1
			20	.28	36	16.8	14.0	12.0	10.5
			30	.35	45	21.0	17.2	14.7	12.9
			40	.40	51	24.0	19.8	17.0	14.9
			60	.49	63	29.0	24.0	21.0	18.2
BROWN	XR8005	XR11005	15	.31	40	18.2	15.2	13.0	11.4
			20	.35	45	21.0	17.5	15.0	13.1
			30	.43	55	26.0	21.0	18.4	16.1
			40	.50	64	30.0	25.0	21.0	18.6
			60	.61	78	36.0	30.0	26.0	23.0

\* Chart data from Spraying Systems Company

**VERIFYING FLOW RATE LIMITS:**

The flow rate of application must be within the range of that specified for the Flow Meter.

FLOW METER MODEL	FLOW RANGE
RFM 5	0.05-5 GPM [0.2-18.9 lit/min]
RFM 15	0.3-15 GPM [1.1-56.8 lit/min]
RFM 55/55A	1-55 GPM [3.8-208 lit/min]
RFM 100	3-100 GPM [11.4-379 lit/min]
RFM 200/200 Poly	15-200 GPM [56.8-757 lit/min]
RFM 400	25-400 GPM [94.6-1514 lit/min]

## 6. CALCULATING "BLAST CAL"

Blast rate entered into BLAST CAL is the application rate in GPM [lit/min] of the system when the BLAST button is depressed.

Blast time entered into BLAST CAL is the length of time in seconds that spraying at the GPM [lit/min] blast rate will continue after the BLAST button is released.

# CONSOLE PROGRAMMING

When entering data into the Console, the entry sequence is always the same. (NOTE: DATA MUST BE ENTERED INTO KEYS 3 THRU 8).

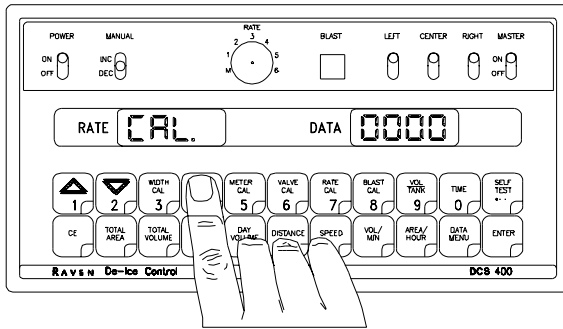

Depress the key in which you wish to enter data.

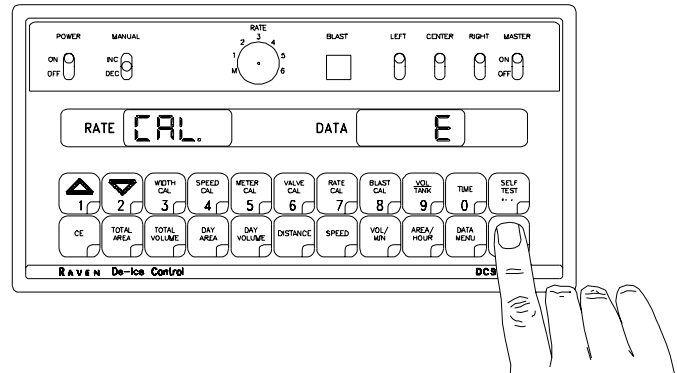

Depress the ENTER key. An "E" will illuminate in the DATA display.

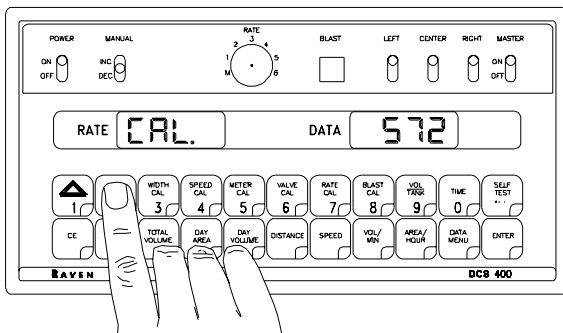

Depress the keys corresponding to the number you wish to enter (i.e. "5", "7", "2"). The numbers will be displayed as they are entered.

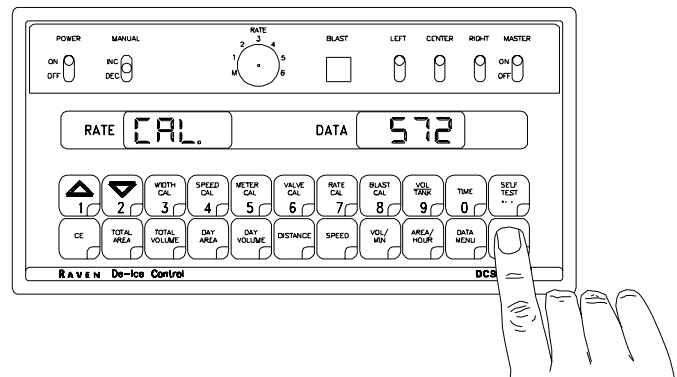

Complete the entry by again depressing the ENTER key.



# 1. INITIAL CONSOLE PROGRAMMING

When you first turn on Console power, after all installation procedures have been completed, the Console will flash "CAL" in the RATE display. This means you must "calibrate", or program, the Console before it can be operated. This is a one-time operation which does not have to be repeated. Turning OFF the POWER ON/OFF switch does not affect the Console memory. All data is retained.

**IMPORTANT:** If an entry selection error is made during Steps 1-6, place the POWER

ON/OFF switch to OFF. Depress  and hold while placing the POWER ON/OFF switch to ON. This will "reset" the Console. The DATA display will show "US", and the RATE display will show "CAL". The following steps must be followed:

1) Display US (lane miles), SI [lane kilometer], or TU {1000 sq. ft.}.

a) Depressing momentarily  steps the DATA display from US to SI.

b) Depressing momentarily  steps the DATA display from SI to TU.

c) Depressing momentarily  steps the DATA display from TU to US.

2) Selecting US, SI, or TU.

a) To select US, SI, or TU, step  until the desired code is displayed in DATA display.

b) Momentarily depress . The DATA display will now display SP1.

3) Display SP1 (wheel drives, speedometer, etc.) or SP2 (radar sensors).

a) Depressing momentarily  steps the DATA display from SP1 to SP2.

b) Depressing momentarily  steps the DATA display from SP2 to SP1.

4) Selecting SP1 or SP2.

a) To select SP1 or SP2, step with  until desired code is displayed in DATA display.

b) Momentarily depress . The DATA display will now display C-Sd.

5) Display C-Sd (Standard Valve), C-F (Fast Valve), or C-FC (Fast Valve Close).

a) Depressing momentarily  steps the DATA display from C-Sd to C-F.

b) Depressing momentarily  steps the DATA display from C-F to C-FC.

c) Depressing momentarily  steps the DATA display from C-FC to C-Sd.

6) Selecting C-Sd, C-F, or C-FC.

a) To select C-Sd, C-F, or C-FC step  until desired code is displayed.

b) Momentarily depress . The DATA display will now display CAL.

7) Procedure to enter WIDTH CAL:

Definition of keys:



Depressing this key displays boom section or lane width in DATA display.  
**EXAMPLE:** Lane width will be displayed as LANE, left boom will be displayed as b-L, center boom will be displayed as b-C, and right boom will be displayed as b-R. Use up or down arrow keys to toggle between the different boom sections and lane width.



Depressing this key allows you to toggle up the different entries within WIDTH CAL, RATE CAL, and BLAST CAL.



Depressing this key allows you to toggle down the different entries within WIDTH CAL, RATE CAL, and BLAST CAL.

8) If the application rate is in gal/mile [lit/km], enter "0" for LANE. Left, center, and right booms do not need any value entered.

**NOTE:** When application rate is in gal/mile [lit/km], the Console **WILL NOT** adjust flow when turning individual booms ON or OFF.

If the application rate is in gal/lane mile [lit/lane km], enter in the actual lane width in feet [meters] for LANE.

$$\begin{aligned} \text{lane mile} &= \text{lane width} \times 5280 \text{ feet} \\ [\text{lane km}] &= \text{lane width} \times 1000 \text{ meters} \end{aligned}$$

Enter in the boom widths calculated per page 10 for b-L, b-C, and b-R. If only one or two booms are being used, enter a "0" for any unused booms.

**NOTE:** When application rate is in gal/lane mile [lit/lane km], the Console will adjust flow when turning individual booms ON or OFF.

9) Enter SPEED CAL in key labelled:



10) Enter METER CAL calibration number in key labelled:



11) Enter VALVE CAL calibration number: C-Sd (2123) in key labelled:  
C-F (0743)  
C-FC (0743)



12) Enter Application Rates 1-6 in either gal/mile or gal/lane mile ([lit/km] or [lit/lane km]) in key labelled:



Use  or  to toggle between r-01 (rate 1) and r-06 (rate 6).

13) Enter the target BLAST RATE in GPM or lit/min, and the amount of time to blast in seconds in key labelled:



**EXAMPLE:**

bL-r -Blast rate in GPM or lit/min.

bL-S -Blast time in seconds.

Use the arrow keys to toggle between the Blast Rate and Blast Time.

**YOU HAVE NOW COMPLETED PROGRAMMING THE CONSOLE**

The flashing "CAL" will now extinguish. If not, repeat procedure starting at Step

7. You may also wish to enter data into keys labelled:



and



although it is not required for operation of the system.

14) Enter the estimated total VOLUME in TANK before you start applying in key

labelled: Each time the tank is refilled, this number must be re-entered.



15) Enter the TIME of day in key labelled:



**NOTE:** This is a 24 hour clock. Therefore, all time after 12:59 p.m., add 12 hours. Thus, 8:30 a.m. is entered as 8:30, but 1:30 p.m. is entered as 13:30

## 2. OTHER DISPLAY FEATURES

1) To display TOTAL AREA covered, momentarily depress key labelled:

To "zero out" this total at any time, enter a "0" in this key.



2) To display TOTAL VOLUME applied, momentarily depress key labelled:

To "zero out" this total at any time, enter a "0" in this key.



3) To display DAY AREA covered, momentarily depress key labelled:

To "zero out" this total at any time, enter a "0" in this key.



4) To display DAY VOLUME applied, momentarily depress key labelled:

To "zero out" this total at any time, enter a "0" in this key.



5) To display DISTANCE (feet) [meter] traveled, momentarily depress key labelled:

To "zero out" this total at any time, enter a "0" in this key.



6) To display SPEED, momentarily depress key labelled:



7) To display VOL/MIN, momentarily depress the key labelled:



8) To display AREA/HOUR, momentarily depress key labelled:



This is an

actual calculation of AREA/HOUR at the present speed you are going. It is not an average over a period of time.

9) To display US, SI, or TU; C-Sd, C-F, or C-FC; and SP1 or SP2 after being selected,

depress key labelled:



These selections will be alternately displayed.

### 3. SELF TEST FEATURE

SELF-TEST allows speed simulation for testing the system while vehicle is not moving. Enter the simulated operating speed in key labelled:



If 6 MPH [10 km/h] is desired, enter 6.0 [10.0]. Verify SPEED by depressing key labelled:



The SELF-TEST speed will clear itself when motion of vehicle is detected by the Speed Sensor. A SPEED CAL value of 900 [230] or greater is recommended when operating in this mode.

**NOTE:** To prevent nuisance clearing of self-test speed, disconnect speed connector on back of Console when Radar Speed Sensors are used.

### 4. SEQUENCE TO ACTIVATE DATA-LOCK

1) Depress  for 5 seconds, NEW CODE message will appear.

2) Enter 4-digit code within 15 seconds. **EXAMPLE:** For 1085, depress:



### 5. SEQUENCE TO CHANGE DATA-LOCK

1) Depress  for 5 seconds, OLD CODE message will appear.

2) Enter 4-digit code within 15 seconds.

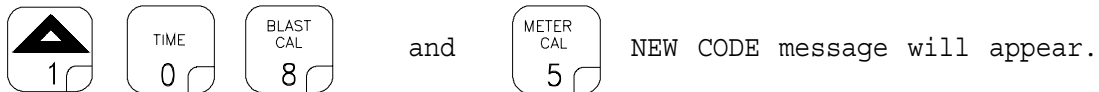

Enter 4-digit code within 15 seconds. **EXAMPLE:** For 1285, depress:



### 6. ENTER MODE SEQUENCE WITH ACTIVATED DATA-LOCK



1) Depress the key into which you wish to enter data.

2) Depress  CODE message will appear. Enter your DATA-LOCK CODE. If CODE is correct, an "E" will appear. Now enter data normally.

\* The DATA-LOCK feature prohibits the entry of data without first entering the DATA-LOCK CODE. If DATA-LOCK is not desired, omit Steps 4, 5, and 6. The DATA-LOCK CODE may be cleared by entering a code of "0" or by resetting the Console.

## 7. POWER DOWN DELAY TIME FEATURE

If the Console is not used for 10 days, it will go into a power down (low power) mode of operation. In this mode, all data will be retained, but the time of day clock will be reset to 1:00. The delay is initially set at 10 days, but can be changed by the user.

- 1) Displaying delay time.
  - a) Depress key labelled:  for 5 seconds, the current delay time (in days) will appear.
- 2) Changing delay time.
  - a) Depress key labelled:  for 5 seconds, the current delay time will appear.
  - b) Enter new delay time (0 to 200 days) using the same procedure as that for entering other data.





**NOTE:** When resetting the Console, the delay time will be reset to 10 days.

## 8. CONSOLE ALARM FEATURE



Console alarm sounds if the application rate is 30% or more away from the target application rate for more than 5 seconds. The "no speed" alarm is 3 beeps, 8 second pause, then repeat.

## 9. DISPLAYING & PROGRAMING AUXILLARY FEATURES

### PRINT MENU

- 1) Console Data Printout.
  - a) Depress key labelled:  DATA display will show P-b (Print Field Begin). To Print Field Begin, depress .
  - b) DATA display will now show P-E (Print Field End). To Print Field End, depress key labelled: .
  - c) While P-E is displayed, if Field Begin is required, depress  to toggle DATA display to P-b. Depress  to Print Field Begin.

### ALARM MENU

- 1) To display ALARM MENU, depress key labelled:  "A on" will be displayed in DATA display.
  - a) Depress momentarily  stops the DATA display between "A on" and "A off". "A on" means alarm is enabled, "A off" means alarm is disabled.
  - b) Depress  to store selection and advance to DISPLAY MENU.

## DISPLAY MENU ("d on" OR "d off")

1) Selecting "d on" or "d off" (enabling or disabling display smoothing).

a) To select "d on" or "d off" step with  until desired code is displayed in DATA display.

b) "d on" means RATE displays application rate when actual rate is within a percentage of application rate. This percentage is determined by the third digit of VALVE CAL value as shown:

Break Point Digit

(3rd digit) of VALVE CAL    2 1 2 3

0 = 1% + Deadband

5 = 25% + Deadband

1 = 3% + Deadband

6 = 30% + Deadband

2 = 7% + Deadband

7 = 35% + Deadband

3 = 10% + Deadband

8 = 40% + Deadband

4 = 20% + Deadband

9 = 45% + Deadband

Actual rate is displayed if unit does not reach deadband within 10 seconds.

"d off" means RATE displays actual rate at all times.

c) Depress  to store selection and advance to PRINT MENU.

## 10. CONTROL VALVE DELAY

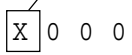
Depress  until DATA display flashes.  Valve Control delay digit

The left most digit is the Control Valve delay digit. This feature allows the user to set a delay between the time the booms are turned on and when the console begins to control the flow rate. A value of 1-9 means a delay of 1-9 seconds respectively. A value of 0 means no delay. This delay is only active if the time between turning off and turning on the booms is less than 30 seconds.



# 11. DECIMAL SHIFT

The steps to programming the Console are the same as those described in the CONSOLE PROGRAMMING section of this manual except for METER CAL. It is during this entry that the decimal point must be shifted to increase the accuracy of the system to accommodate the application rates of low volume systems.

The following is an example of how a meter calibration constant of 730 would be entered:

The sequence to shift the decimal is to depress key labelled:



Enter    as the METER CAL constant.

The sequence to unshift the decimal is to omit the key labelled:



Simply enter the METER CAL constant:



Shifting the decimal permits a times 10 resolution of the data. The following table illustrates this resolution:

KEY	UNSHIFTED	SHIFTED
RATE Display	000.0	00.00
RATE 1-6 CAL	000.0	00.00
BLAST RATE CAL	000.0	00.00
VOL/TANK	0000	000.0
TOTAL VOLUME	0000	000.0
FIELD VOLUME	0000	000.0
VOL/MIN	0000	000.0

When entering RATE 1-6 CAL and BLAST RATE CAL, remember that 2 gal/lane mile [20 lit/lane km] is entered as 2.00 [20.0].

# INITIAL SYSTEM SET-UP

- 1) Fill tank with water only. (If positive displacement pump is used, open pressure relief valve, PRV).
- 2) Place MASTER ON/OFF switch to ON and LEFT, CENTER, and RIGHT switches to OFF.
- 3) Place RATE switch to M (manual).
- 4) Place POWER ON/OFF switch to ON.
- 5) Verify that WIDTH CALS, SPEED CAL, METER CAL, VALVE CAL, RATE CALS, and BLAST CAL have been entered correctly into the Console. In SELF TEST mode, enter the normal vehicle operating speed.
- 6) Run pump at normal operating RPM.
- 7) If centrifugal pump is used, proceed with Step 8. If positive displacement pump is used, set pressure relief valve (PRV) to 65 PSI [450 kPa].
- 8) Verify that boom valves operate and that no nozzles are plugged by operating the LEFT, CENTER, and RIGHT switches.
- 9) Place LEFT, CENTER, and RIGHT switches to ON.
- 10) Hold the MANUAL switch in INC position until pressure is at its maximum. This assures that the motorized Control Valve is fully open. Verify maximum pressure and RATE. (Pressure gauge is not supplied with the DCS 400).

**NOTE:** A pressure gauge MUST be installed to properly monitor the system.

- 11) Adjust agitator line hand valve for desired agitation. Verify maximum pressure is still present.
- 12) Hold the MANUAL switch to DEC position until pressure is at its minimum. This assures that the motorized Control Valve is fully closed. Verify minimum pressure and RATE.



# INITIAL SYSTEM ROAD TEST

- 1) Drive down road at target speed with all BOOM switches and MASTER switch OFF. Verify SPEED readout on Console.
- 2) Place MASTER and all BOOM switches ON. Place the RATE switch to 1 (one). Increase or decrease speed by 5 MPH [8 km/h]. The system should automatically correct to the target application rate.
- 3) If for any reason, the system is unable to correct to the desired RATE, check for an empty tank, a plugged line, a malfunctioning pump, improper vehicle speed, or a defect in the system.
- 4) If the system does not appear to be correcting properly, first review INITIAL SYSTEM SET-UP, then refer to SERVICE MANUAL and TROUBLESHOOTING GUIDE.
- 5) When stopping, switch the MASTER switch OFF to shut off flow. This also shuts off the area totalizer. When C-FC is selected, and a Fast Close Control Valve is used, flow will shut off automatically when speed is zero.
- 6) Verify area covered and volume used.

# PREVENTIVE MAINTENANCE

Preventive maintenance is most important to assure long life of the system. The following maintenance procedures should be followed on a regular basis:

- 1) Flush entire system with water after use of suspension type chemicals. Failure to clean system can result in crystallization of chemicals which may plug the Flow Meter, lines, and/or tips.
- 2) Flush and drain system before storing. **FREEZING TEMPERATURES MAY DAMAGE FLOW METER IF WATER IS NOT DRAINED.**
- 3) Remove Flow Meter at the end of each season. Clean Flow Meter turbine and inlet hub. Clean off all metal filings and wetttable powders which have hardened on the plastic and metal parts. Check the inlet hub and turbine assembly for worn or damaged turbine blades and bearings. Flush Flow Meter with clear water and drain.

<b>KEEP FROM FREEZING</b>
---------------------------

- 4) Remove Console when not in use for extended periods.

# TROUBLESHOOTING GUIDE

<u>PROBLEM</u>	<u>CORRECTIVE ACTION</u>
1) NO DISPLAY LIGHTS WITH POWER ON.	1) Check fuse on back of Console 2) Check battery connections. 3) Check operation of POWER ON/OFF switch. 4) Return Console to your Dealer to replace Processor Board Assembly.
2) ALL KEYBOARD LIGHTS ON AT SAME TIME.	1) Return Console to your dealer to replace Face Plate Sub-assembly.
3) A DIGIT CANNOT BE ENTERED VIA KEYBOARD.	1) Return Console to your Dealer to replace Face Plate Sub-assembly.
4) AN INDICATOR LIGHT ON A KEY WILL NOT ILLUMINATE.	1) Return Console to your Dealer to replace Face Plate Sub-assembly and/or Processor Board Assembly.
5) CONSOLE DISPLAYS FLASHING "CAL" WHENEVER VEHICLE ENGINE IS STARTED.	1) Check battery voltage and battery connections.
6) CONSOLE DISPLAYS FLASHING "CAL" WHENEVER MASTER SWITCH IS TURNED ON OR OFF.	1) Check battery voltage and battery connections.
7) CONSOLE DISPLAYS FLASHING "CAL" WHENEVER SPEED IS CHANGED.	1) Check battery voltage and battery connections.
8) "TIME" FUNCTION IS INACCURATE OR DRIFTING.	1) Return Console to Dealer to replace Processor Board Assembly.
9) ONE DISPLAY DIGIT HAS ONE OR MORE MISSING SEGMENTS.	1) Return Console to Dealer to replace LCD Display Board Assembly.
10) SPEED DISPLAY "0"	1) Check Speed Sensor cable connector and plug on back of Console for loose pins. 2) Clean pins and sockets on Speed Sensor cable connectors. 3) If no extension cable is used, replace Speed Sensor. 4) If 24 foot Speed Sensor Extension cable is used, see Appendix 2.
11) SPEED INACCURATE OR UNSTABLE (SPEEDOMETER SPEED SENSOR).	1) Wiggle cable at the Speed Sensor connector. If speed is displayed, tighten connector or replace Transducer Assembly. (cont. next page)

- |   |   |
|---|---|
| 12) RATE READS "0000".                                | <ul style="list-style-type: none"> <li>2) Check Speedometer Cable Adaptor, Key, and Transducer Assembly for proper connections and engagement.</li> <li>3) Check for kinked Speedometer cable or too sharp of a bend.</li> <li>4) Replace Speedometer Transducer Assembly.</li> </ul>   |
| 13) RATE INACCURATE OR UNSTABLE.                      | <ul style="list-style-type: none"> <li>1) Verify SPEED is registering accurately. If SPEED is zero, refer to Troubleshooting Problem 10.</li> <li>2) Verify TOTAL VOLUME is registering flow. If not, refer to Troubleshooting Problem 16.</li> </ul>   |
| 14) CAN NOT VARY RATE IN MANUAL OPERATION OR IN AUTO. | <ul style="list-style-type: none"> <li>1) Verify that all numbers "keyed in" Console are correct. Verify SPEED is registering accurately. If SPEED is inaccurate, refer to Troubleshooting Problem 11.</li> <li>2) In M (manual) operation, verify that RATE display (GAL/lane mile) holds constant. If not, refer to Troubleshooting Problem 17.</li> <li>3) In M (manual) operation, check low end and high end pressure range. Pressure range must be per Initial System Set-up on page 22. If pressure can not be adjusted manually, refer to Troubleshooting Problem 16.</li> <li>4) If problem persists, return Console to Dealer to replace Processor Board Assembly.</li> </ul> |
|   | <ul style="list-style-type: none"> <li>1) Check cabling to motorized Control Valve for breaks.</li> <li>2) Check connections in cabling for cleanliness.</li> <li>3) Verify that there is voltage at the valve connector by placing MASTER switch ON; RATE switch to M; and POWER switch to ON. Manually operate INC/DEC switch to verify voltage.</li> <li>4) Verify that valve is turning, if not, replace motorized Control Valve.</li> </ul>  |

15) SPRAYER PRESSURE IS CORRECT BUT RATE IS LOW.

- 1) Verify that nozzle strainer screens or Check Valves are not plugged.
- 2) Verify that pressure at each boom is the same.
- 3) Verify all nozzles are of proper and same orifice size. See page 13 of Installation Manual.

16) TOTAL VOLUME DOES NOT REGISTER.

- 1) Check Flow Meter cable for breaks and shorts. See Appendix 3 for test procedure.
- 2) Check internals of Flow Meter; clean and adjust. See Appendix 4 for Flow Meter cleaning and adjustments.
- 3) Replace Flow Meter Transducer.

17) TOTAL VOLUME REGISTERS FLOW INACCURATELY.

- 1) Verify that arrow on Flow Meter is pointing in direction of flow.
- 2) See Appendixes 4 and 5.

18) MOTORIZED CONTROL VALVE ROTATES MORE THAN 1/4 TURN.

- 1) Replace motorized Control Valve.

19) WATER INSIDE COVER OF MOTORIZED CONTROL VALVE.

- 1) Replace Isolation Flange Assy. and Coupler Shaft.
- 2) Replace entire motorized Control Valve, if PC Board or Motor is corroded and will not run.

20) BOOM VALVE(S) WILL NOT OPERATE.



- 1) Check cable for wires with breaks.
- 2) Check connectors for cleanliness.
- 3) Check LEFT/CENTER/RIGHT and MASTER switches for operation.
- 4) Replace boom valves.

# APPENDIX 1

## SPEEDOMETER SPEED SENSOR INSTALLATION AND CALIBRATION

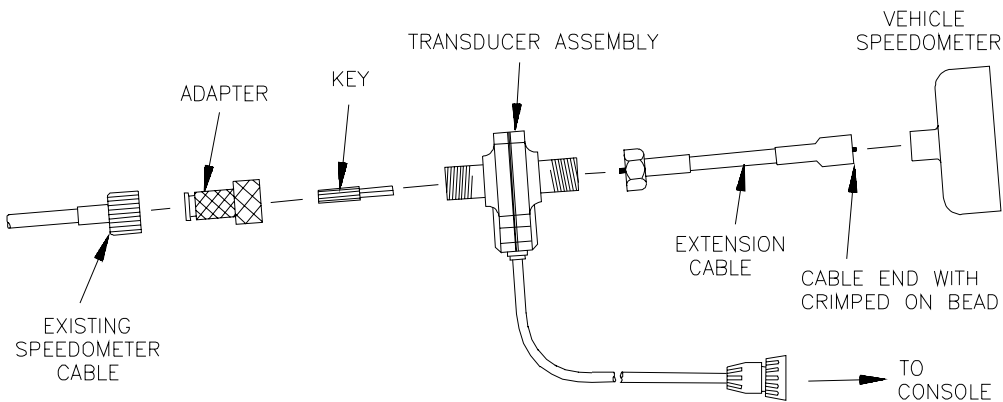
- 1) Remove the existing speedometer cable from the back of the vehicle speedometer. Pull cable through fire wall into engine compartment.
- 2) Install adapter and key on speedometer cable and connect to Transducer Assembly. (Some units do not use adapter and key).
- 3) Connect Extension Cable to Transducer Assembly.
- 4) Push Extension Cable through fire wall and re-install on speedometer.
- 5) Connect the cable on the Transducer Assembly to the Console.



- 6) Secure all Cables with plastic cable ties. The unit is now ready for calibration with your vehicle.
- 7) Complete INITIAL CONSOLE PROGRAMMING on page 15 before doing this procedure.
- 8) Enter "0" in key labelled: 
- 9) Enter 612 [155] in key labelled: 
- 10) Drive 1 mile [1 km]. (**CAUTION:** Do not use vehicle odometer to determine distance. Use section lines or highway markers).
- 11) Read DISTANCE by depressing key labelled: 

DISTANCE should read a value of approximately 5280 [1000]. If it reads between 5200-5350 [990-1010], the SPEED CAL for your vehicle is 612 [155].

If the DISTANCE display reads any other value, divide SPEED CAL by the value observed in DISTANCE, then multiply by 5280 [1000]. This will give you the correct value to enter for SPEED CAL. You must round off to the nearest 3 digit number.

**EXAMPLE:** Assume DISTANCE read 5000 [980].

ENGLISH UNITS:

$$= \frac{612 \times 5280}{5000} = 646.3$$

METRIC UNITS:

$$= \frac{[155] \times 1000}{980} = 158$$

12) The number to enter for SPEED CAL is 646 [158].

13) Recheck the new SPEED CAL derived above.

- a) Zero out DISTANCE display as in Step 8.
- b) Enter the new SPEED CAL number as in Step 9.
- c) Repeat Steps 10, 11, and 12.

## APPENDIX 2

# PROCEDURE TO TEST SPEED SENSOR EXTENSION CABLES

Disconnect extension cable from Speed Sensor Assembly cable. Hold extension cable connector so that keyway is pointing in the 12 o'clock position.

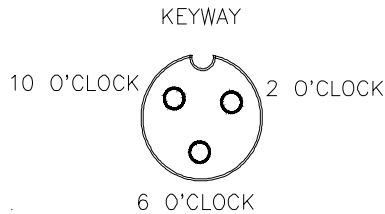

- 1) 2 o'clock socket is power.
- 2) 10 o'clock socket is ground.
- 3) 6 o'clock socket is signal.

#### VOLTAGE READINGS

- 1) 10 o'clock to 6 o'clock (+5 VDC).
- 2) 10 o'clock to 2 o'clock (+5 VDC).

Procedure to check cable: (NOTE: Console must be programmed with SP1 selected).

1) Enter SPEED CAL number of 1000 in key labelled:



2) Depress key labelled:



3) With small jumper wire (or paper clip), short between 10 o'clock and 6 o'clock sockets with a "short-no short" motion. This should cause a speed reading to be displayed in the Console. Each time a contact is made, the DISTANCE total should increment up 1 or more counts.

4) If DISTANCE does not count up, remove the section of cable and repeat test at connector next closest to console. Replace defective cable as required.

5) Perform above voltage checks.

6) If all cables test good, replace speed sensor.

**NOTE:** After testing is complete, re-program Console with correct SP1/SP2 selected if needed. Re-enter correct SPEED CAL number before application.

## APPENDIX 3

### PROCEDURE TO TEST FLOW METER CABLES

Disconnect cable from Flow Meter. Hold Flow Meter cable so that the keyway is pointing in the 12 o'clock position:

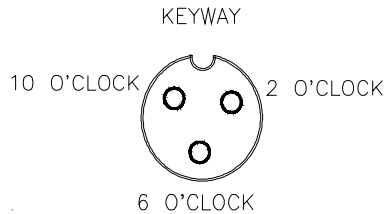

- 1) 2 o'clock socket is ground.
- 2) 10 o'clock socket is power.
- 3) 6 o'clock socket is signal.

#### VOLTAGE READINGS

- 1) 2 o'clock to 6 o'clock (+5 VDC).
- 2) 2 o'clock to 10 o'clock (+5 VDC).

Procedure to check cable:

1) Enter a METER CAL number of one (1) in key labelled:



2) Depress key labelled:



3) Place LEFT/CENTER/RIGHT and MASTER switches ON.

4) With small jumper wire (or paper clip), short between 2 o'clock and 6 o'clock sockets with a "short-no short" motion. Each time a contact is made, the TOTAL VOLUME should increment up 1 or more counts.

5) If TOTAL VOLUME does not count up, remove the section of cable and repeat test at connector next closest to Console. Replace defective cable as required.

6) Perform above voltage checks.

7) If all cables test good, replace Flow Meter.

**NOTE:** After testing is complete, re-enter correct METER CAL number before application.





## APPENDIX 4

# FLOW METER MAINTENANCE AND ADJUSTMENT PROCEDURE

- 1) Remove Flow Meter from sprayer and flush with clean water to remove any chemicals.
- 2) Remove flange bolts from the Flow Meter.
- 3) Remove the turbine hub and turbine from inside Flow Meter.
- 4) Clean turbine and turbine hub of metal filings and any other foreign material, such as wettable powders. Confirm that the turbine blades are not worn. Hold turbine and turbine hub in your hand and spin turbine. It should spin freely with very little drag.
- 5) If transducer (XDCR) assembly is replaced or if turbine stud is adjusted or replaced, verify the turbine fit before reassembling. Hold turbine hub with turbine on transducer. Spin turbine by blowing on it. Tighten turbine stub until turbine stalls. Loosen turbine stud 1/3 turn. The turbine should spin freely.
- 6) Re-assemble Flow Meter.
- 7) Using a low pressure (5 psi) [34.5 kPa] jet of air, verify the turbine spins freely. If there is drag, loosen hex stud on the bottom of turbine hub 1/16 turn until the turbine spins freely.
- 8) If turbine spins freely and if cables have checked out per Appendix 3, but Flow Meter still is not totalizing properly, replace Flow Meter transducer.

## APPENDIX 5

### PROCEDURE TO RE-CALIBRATE FLOW METER

- 1) Enter a METER CAL number of 10 [38] in the key labelled: 
- 2) Enter a TOTAL VOLUME of 0 in the key labelled: 
- 3) Switch OFF all booms.
- 4) Remove a boom hose and place in calibrated 5 gallon [19 liter] container.
- 5) Switch ON appropriate boom switch and MASTER switch. Pump exactly 10 gallons [38 liters].
- 6) Readout in TOTAL VOLUME is the new METER CAL number. This number should be within +/- 3% of the number stamped on the tag on Flow Meter.
- 7) Repeat this procedure several times to confirm accuracy. (Always "zero out" the TOTAL VOLUME display before retesting).

**NOTE:** For greatest precision, set METER CAL to 100 and pump 100 gallons (378 liters) of water.

8) To verify Flow Meter calibration, fill applicator tank with a predetermined amount of measured liquid (i.e. 250 gallons). **DO NOT RELY ON GRADUATION NUMBERS MOLDED INTO APPLICATOR TANK.** Empty the applicator tank under normal operating conditions. If the number displayed under TOTAL VOLUME is different from the predetermined amount of measured liquid by more than +/- 3%, complete the following calculation.

**EXAMPLE:**

METER CAL	= 720 [190]
TOTAL VOLUME	= 260 [984]
Predetermined amount of measured liquid	= 250 [946]

$$\text{Corrected METER CAL} = \frac{\text{METER CAL} \times \text{TOTAL VOLUME}}{\text{Predetermined amount of measured liquid}}$$

ENGLISH UNITS:	METRIC UNITS:
= $\frac{720 \times 260}{250} = 749$	= $\frac{[190] \times [984]}{[946]} = [198]$

Corrected METER CAL = 749 [198]

- 9) Enter corrected METER CAL before resuming application.

# APPENDIX 6 REMOTE SWITCH OPTION

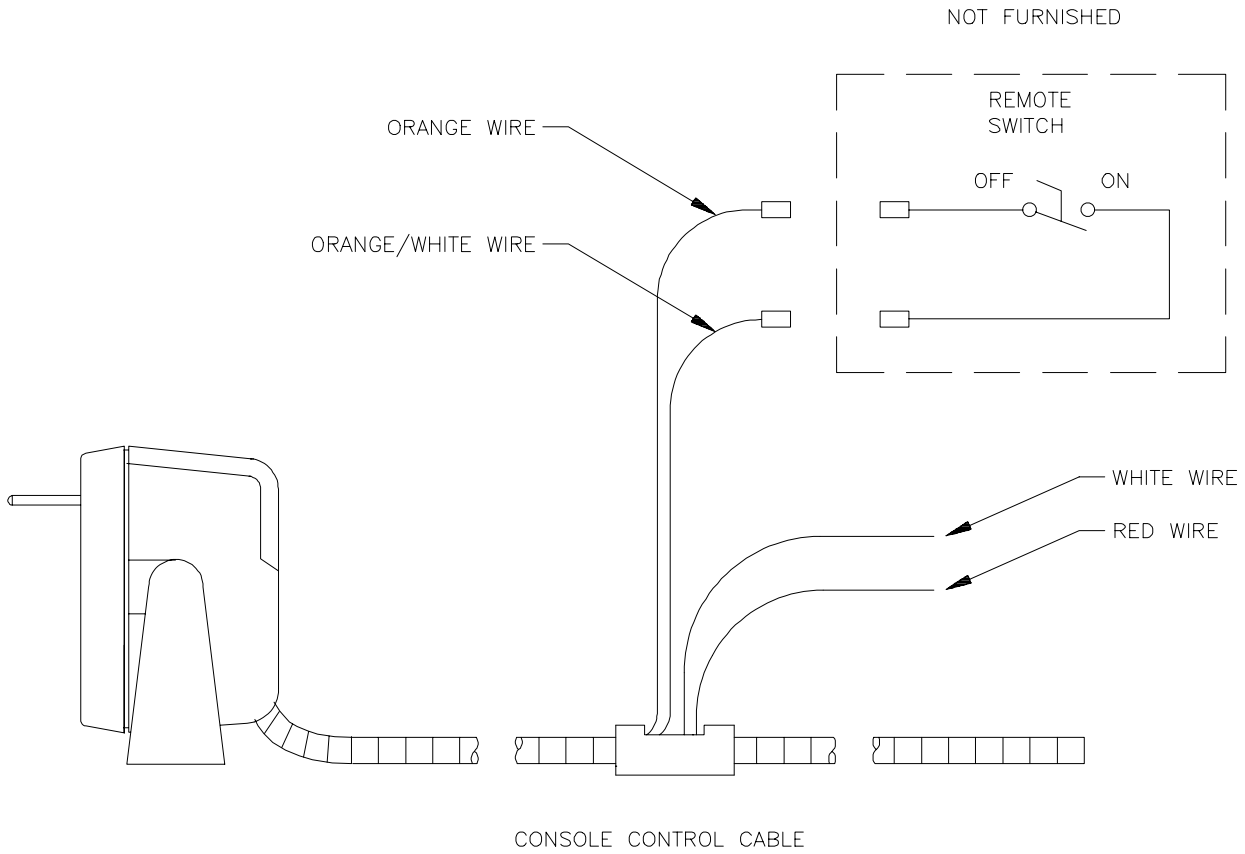

The REMOTE switch when installed is in parallel with the MASTER switch; therefore switching on the REMOTE switch or the MASTER switch will energize the boom valves.

# APPENDIX 7 SERIAL INTERFACE

1) Cable Pinout (P/N 115-0159-624), supplied with Thermal Printer Kit (P/N 117-0159-529).

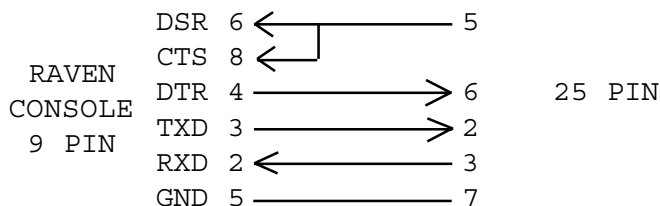

2) Changing RATE 1 CAL by remote computer.

- a) Configuration of RS-232C serial port:
  - 1200 Baud Rate
  - NO Parity
  - 8 Data Bits
  - 1 Stop Bit
- b) Data stream to Raven Console.

**EXAMPLE:** Change RATE 1 to 123.4

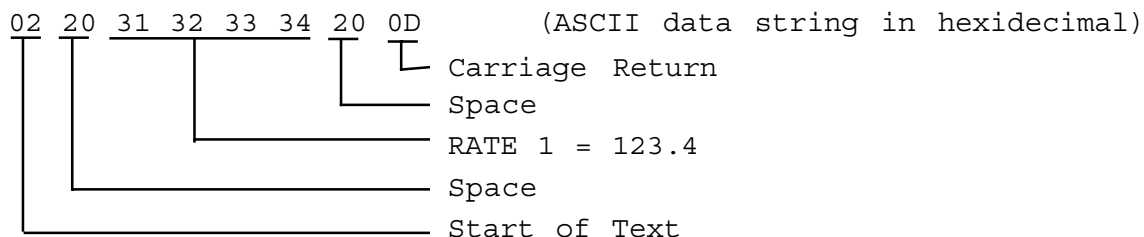

- c) Decimal point is not sent from PC to Raven Console.
- d) End of field printout is sent from Raven Console to PC whenever PC sends a rate to Console.
- e) Optional 9 pin to 9 pin cable pinout (P/N 115-0159-822).

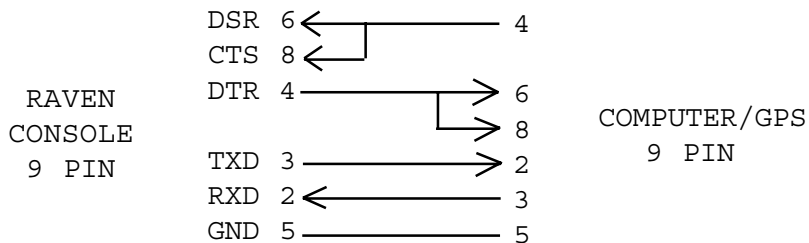







# RAVEN INDUSTRIES

## LIMITED WARRANTY

### WHAT IS COVERED?

This warranty covers all defects in workmanship or materials in your Raven Flow Control Product under normal use, maintenance, and service.

### HOW LONG IS THE COVERAGE PERIOD?

This warranty coverage runs for 12 months from the purchase date of your Raven Flow Control Product. This warranty coverage applies only to the original owner and is not transferrable.

### HOW CAN YOU GET SERVICE?

Bring the defective part, and proof of date of purchase, to your local dealer. If your dealer agrees with the warranty claim, he will send the part, and proof of purchase to his distributor or to Raven for final approval.

### WHAT WILL RAVEN INDUSTRIES DO?

When our inspection proves the warranty claim, we will, at our option, repair or replace the defective part and pay for return freight.

### WHAT DOES THIS WARRANTY NOT COVER?

Raven Industries will not assume any expense or liability for repairs made outside our plant without written consent. We are not responsible for damage to any associated equipment or product and will not be liable for loss of profit or other special damages. The obligation of this warranty is in lieu of all other warranties, expressed or implied, and no person is authorized to assume for us any liability. Damages caused by normal wear and tear, mis-use, abuse, neglect, accident, or improper installation and maintenance are not covered by this warranty.

